

NORTHERN CONTOURS®

PRODUCT GUIDE

CABINET COMPONENT PRODUCT GUIDE





LEVEL | FENIX NTM NERO INGO



ELEGANTE II | PALOMINO



SHAKER SLIM | SAGE SUPERMATTE



ELEGANTE II | MIDNIGHT SUPERMATTE



TM502 | RUSTIC LIGHT OAK



Since 1992, we have evolved to recognize the importance of providing unique, design-driven products to the industry. With that in mind, we are pleased to offer a wide variety of cabinet doors and components to fit design styles, from contemporary and modern to transitional or traditional. This technical guide houses the detailed information you'll need to create custom looks with our versatile products.

By design, our products work together affording you endless possibilities for material, color and texture combinations.

Unleash your creative vision, and let Northern Contours help you produce designs that speak to your signature style.



CUSTOMER CARE

T | 877-998-1814
 F | 218-736-7919
 info@northerncontours.com
 orders@northerncontours.com
 www.northerncontours.com

COVER ISLAND: ROGUE VALLEY PEAR
 CABINETS: NORDIC WHITE SUPERMATTE

CONTENTS

ORDERING INFORMATION 2

DRAWER BOXES 4

LEVEL 6

5-PIECE 12

3D LAMINATES 22

WOOD VENEER 56



1 Year Limited Warranty for unfinished Wood Veneer and MDF components.
 5 Year Limited Warranty for finished 2DL, 3DL, 5PC, and TFL components.

We strive to offer the best in quality and performance. Therefore, Northern Contours reserves the right to change materials or specifications as necessary.

This printed representation of colors and woodgrains may vary from the actual product. Please view a product sample prior to making your final selection.

All measurements in this catalog are in inches unless otherwise noted. For a complete selection of styles and materials, please visit our website.

©2025 Northern Contours, Inc.



STANDARD TERMS*

These Standard Terms and Conditions govern all orders and any other terms and conditions or specifications in your purchase order or other documents are specifically excluded and superseded by these terms. All accounts are initially set up as PrePay unless you apply for terms. Upon approval, standard payment terms are net 30 days. If errors or discrepancies are found on your invoice, immediately contact Customer Care at 877-998-1814.

CUSTOMER CARE CONTACTS

Hours | M – F, 8 AM to 4:30 PM CST
Phone | 877-998-1814 Fax | 218-736-7919
Email | orders@northerncontours.com

PLACING AN ORDER

Orders are accepted via Northern Contours Ordering Portal by logging in at www.northerncontours.com, by submitting a Northern Contours order form via email or fax, or by EDI. Phone orders are not accepted. Order forms can be downloaded at www.northerncontours.com/downloads. Orders may be accepted 24 hours a day, 7 days a week.

- Orders may be placed in inches or millimeters.
- Order the exact size to the nearest 1/32" or nearest millimeter.
- Always order in Width x Height measurements.
- All pricing is per square foot and rounded to the nearest hundredth of a sq. ft. FOB Northern Contours facility.
- 1 sq. ft. minimum charge applies on 3DL, LEVEL and Wood Veneer components. 1.5 sq. ft. minimum applies on 5-pc components. 2 sq. ft. minimum charge applies on LEVEL frames, wood veneer frames, fillers, overlays and undersized components.
- Components with a glass insert have a 3 sq. ft. minimum and components with a frosted acrylic insert have a 1.5 sq. ft. minimum.
- 2 lineal ft. minimum charge applies on floating shelves.
- \$25 minimum order charge applies prior to freight, packaging and other fees.

Incomplete orders will be placed on hold until missing information is obtained. Orders on hold are not released for production. Failure to provide needed information may extend lead time. We reserve the right to change materials or specifications as necessary.

LEAD TIMES

Lead times vary per product; typically orders ship within ten business days. Any delivery times are estimates only. The day after you receive your acknowledgement is business day one. Please contact Customer Care for the most up-to-date lead times.

ORDER ACKNOWLEDGMENTS

All orders are generally acknowledged within 24 hours. Contact Customer Care if you do not receive an acknowledgement.

- All orders enter production the day following the acknowledgment receipt to allow for changes.
- Any order discrepancy must be reported to Customer Care within 24 hours of receipt.
- Northern Contours is not liable for unreported or not timely reported order errors or discrepancies.

ORDER CHANGES & CANCELLATIONS

- Changes or cancellations must be received in writing within 24 hours of acknowledgment.
- Any changes made after the 24 hour cut-off will result in a 50% to 100% restock fee at our discretion.

RUSH ORDER SERVICE

Rush orders are available for most components and are subject to these limitations and rush fee or upcharge, whichever is greater.

- 1 day lead time = \$125 rush fee or 100% upcharge
- 2 day lead time = \$100 rush fee 50% upcharge
- 3 day lead time = \$75 rush fee 30% upcharge
- 4 day lead time = \$50 rush fee 25% upcharge
- 5 day lead time = \$25 rush fee 20% upcharge
- 6 day lead time = \$25 rush fee 15% upcharge

- Rush order maximum 100 sq. ft. per customer, per day.
- Rush orders are subject to approval. Not all levels of rush service are available for all products. Exceptions may apply due to product type, component size, or order size.
- Lead time begins 1 business day after the order is committed and acknowledgement is received. This is subject to change if the order is on credit hold.
- Rush service is not available on orders that include glass inserts.
- Glazed rush orders require 5 (FIVE) business day minimum.
- Rush orders will ship LTL or UPS Ground and include standard packaging. Additional packaging and express deliveries are available for an additional charge.
- Rush orders cannot be cancelled or changed.

QUOTES & CUSTOM PRODUCTS

Complete custom capabilities are available. We provide a complimentary quote service for standard projects. Project quotes requiring detailed drawings may have a fee. We may cancel a quote at any time before it is accepted.

PACKAGING*

Northern Contours packaging exceeds common carrier standards. LEVEL A, standard packaging is included in all published list prices. Packaging costs for additional options are net charges and discounts do not apply.

SHIPPING & DELIVERY*

Orders will ship LTL or UPS based on the component size, order size and delivery date requirements. Delivery times represent best estimate only. Northern Contours shall not be liable for any damage or delay due to an act of terrorism, fire, act of God, pandemic, civil disorder, strike, labor or material shortage, act(s) of government, or other causes beyond our reasonable control.

DAMAGE, DEFECTS OR MISSING PRODUCT*

All damage and defects, concealed or not, and missing product must be reported within 5 days of receipt to Northern Contours Customer Care at 877-998-1814. Please inspect the contents of your shipment before signing your delivery receipt.

HEAT RESISTANCE

The KCMA standard for heat resistance requires that doors withstand 24 hours at 120°F (49°C) and 70% humidity without showing discoloration, blistering or other material failure. All Northern Contours doors and drawer fronts exceed this standard. Our average heat resistance is 185°F (85°C); the range is 175°F–210°F (79°C–99°C).



HEAT SHIELDS

Heat shields are an excellent product for protecting cabinets from possible damage caused by excessive ambient heat (temperatures beyond the ANSI/KCMA standard). Size is 1.56" x 30" and 0.05" thick. Heat shields are fabricated from cold rolled steel, finished in a durable White, Almond or Black powder coat, and predrilled for easy installation.

Heat Shields should be installed on cabinets near self-cleaning ovens, broilers and dishwashers. Place heat shield against cabinet frame. Heat shield should be even with the front edge of the cabinet doors with countersunk holes towards back of cabinet.

HINGE BORING & HINGES

Unless otherwise specified, hinge boring will be 0.5" deep. Patterns and standard placement on 3/4" thick components will be as follows:

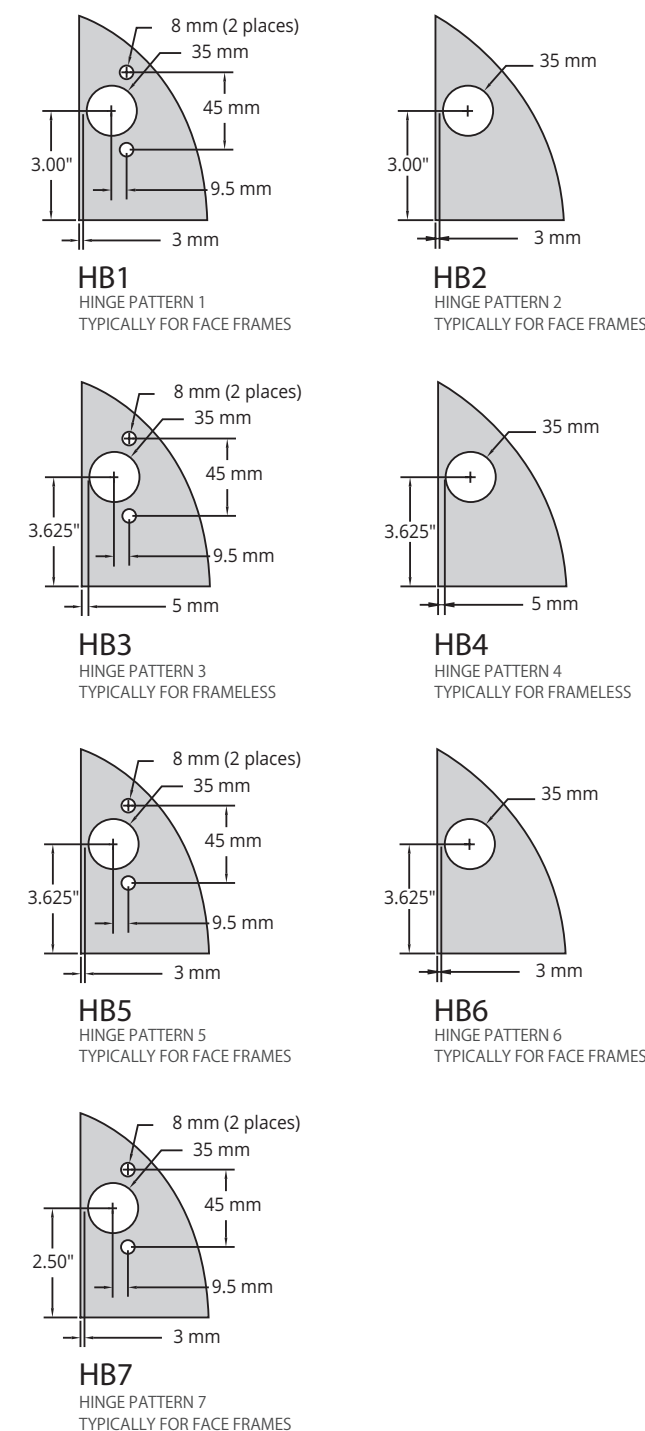
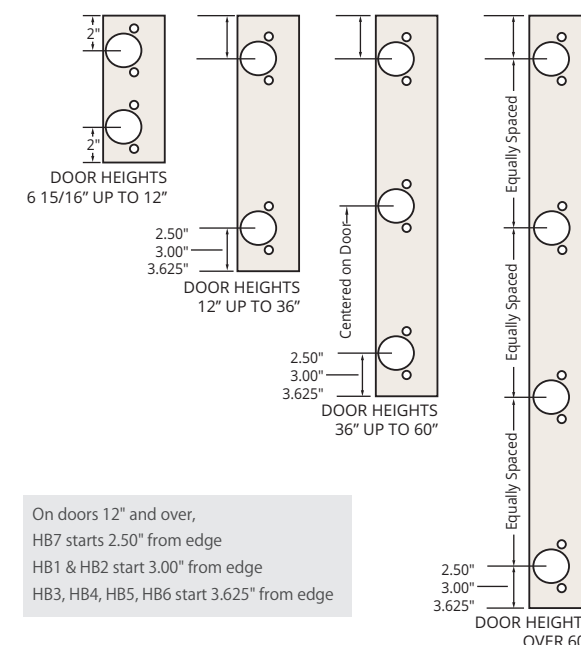

Face frame compact hinges for 1/2" and 1-1/4" overlay are available in both standard and soft close. For frameless cabinets, 110 degree soft close hinges are available for purchase.

*Information provided is a condensed version. See Northern Contours Service Policy on our website for complete details.

1

DRAWER BOXES

miter fold, flat pack, quick assembly

PRODUCT SPECIFICATIONS

Drawer boxes are produced with 3D Laminate (3DL) on a 1/2" engineered core. Bottom panels are double sided thermally fused laminate (TFL). Available in 3", 4" or 7" heights with a standard depth of 21" and widths of 6" - 32", rounded to nearest 1/32". 4" widths can be manufactured, but will not work with the undermount slide hardware kit.



Back of drawer box will be machined to accommodate undermount slide hardware.



CLEANING AND CARE

Clean using mild soap and a damp cotton cloth, mild kitchen or glass cleaning products or denatured alcohol. Bleach (a 2% mixture) can be used as a disinfectant on most surfaces. Test on a non-visible spot before using. Avoid any abrasive materials, solvent based cleaners, harsh chemicals or any brushes or scouring pads. DO NOT USE ACETONE.

HARDWARE KIT

Blum undermount BLUMOTION soft close slides with locking devices. Sold as a set of 2. Rear mounting brackets, typically required for use with face frame cabinetry, are sold individually. You will need 2 per drawer box.



ASSEMBLY AND INSTALLATION

Drawer Boxes can be assembled quickly with just glue and provided dowels. Visit Northern Contours (@NContours) on YouTube for step-by-step assembly and installation instructions.



DRAWER BOXES

PRODUCT SPECIFICATIONS

3" DRAWER BOX



4" DRAWER BOX



7" DRAWER BOX



PROFILE SPECIFICATIONS

CONSTRUCTION	Profile wrapped, miter fold, flat-pack
FACE MATERIAL	White 3DL
BOTTOM PANEL	1/4" White TFL
CORE	1/2" engineered core

ADDITIONAL OPTIONS

HARDWARE KIT	Blum undermount BLUMOTION soft close slides with locking devices. Sold as set of 2.
MOUNTING BRACKET	Rear mounting brackets sold individually. Typically required for use with face frame cabinetry.

SIZE PARAMETERS

HEIGHT	3", 4", 7"
LENGTH	21"
WIDTH	6" to 32", 4" minimum without undermount slides



2

LEVEL edgebanded shakers and slabs

FENIX NTM SPECIFICATIONS

FENIX NTM® features nanotechnology that is characterized by next generation acrylic resins, hardened and fixed with Electron Beam Curing process. With low light reflectivity, the surface of FENIX NTM® is extremely opaque, anti-fingerprint, and features a soft touch. Available with standard TFL backer or double sided FENIX NTM®.



ACRYLIC SPECIFICATIONS

High gloss Acrylic components feature an ABS (Acrylonitrile Butadiene Styrene) colored layer, which is permanently fused with a clear, ultra-high gloss acrylic top layer. ABS is an ecologically responsible, impact resistant, mechanically and thermally resilient, high quality thermoplastic. Available with standard TFL backer or double sided Acrylic.

WIRED SPECIFICATIONS

High gloss Wired 2DL is PVC material for flat lamination only. Available with standard TFL backer.

TFL SPECIFICATIONS

Textured thermally fused laminate (TFL) is made by fusing a resin-impregnated sheet directly to a substrate. Heat and pressure activate the resin in the saturated TFL sheet, creating a cross-linked bond with the engineered core. Components are double sided.

PROTECTIVE PEEL COAT

A protective peel coat is applied to many LEVEL products. Do not expose to direct sunlight before removal. Remove promptly after cabinet installation but prior to decorative hardware. Do not use sharp objects to remove. Avoid sliding the panels on the outer surface.

BOARD SPECIFICATIONS

Components are made with a high quality, CARB Phase 2 ATCM 93120 compliant, 3/4" engineered core. An engineered core provides a stable, consistent substrate, virtually eliminating warping. LEVEL components have the option of a color coordinated TFL back or matching material on the face and back. See availability charts on page 7.

EDGE BANDING SPECIFICATIONS

Edgebanding options include Matching, 2-Part (on select colors) 3D Aluminum, and Brushed Steel. Edgebanding is available for purchase in rolls; roll length varies by type.

DIRECTIONAL MATERIALS

FENIX NTM® and Metallic Acrylics are directional materials. Installation, in-use position and lighting can make a difference in the sheen and overall appearance. Please refer to the arrows on the peel coat and install with arrows pointing in the same direction.

OVERLAYS

Overlays will be edgebanded on all four sides to match door and drawer fronts. Order Cut-to-Size Panels if raw edges are desired.

SHEET STOCK

All edges are raw. TFL sheets available double sided in 1/4" and 3/4". FENIX NTM® Acrylic and Wired laminated sheets available in 1/8", 1/4" 1/2", 5/8" and 3/4". See availability grid for details.

CUT-TO-SIZE PANELS

Raw edges are standard. TFL panels available double sided in 1/4" and 3/4". FENIX NTM® Acrylic and Wired laminated panels available in 1/8", 1/4" 1/2", 5/8" and 3/4". See availability grid for details.

NORLAM

Material laminated to a semi-rigid backer that can be applied with contact adhesive. Available in 4' x 8' sheets.

RAW MATERIALS

Raw Acrylic is available in 4' x 8' sheets. Raw Wired 2DL is available by the lineal foot, measuring a minimum of 52" in usable width.

PRESSURE SENSITIVE ADHESIVE (PSA)

Acrylic or Wired 2DL with a pressure sensitive adhesive developed specifically for cabinet refacing applications. Acrylic is available in 4' x 8' sheets. Wired 2DL is available in 4' x 8', 4' x 10', or 4' x 12' sheets. 4' x 8' sheets can be cut into two 2' x 8' at no charge or cut into 2" or 3.5" strips for a fee.

FRAMES

LEVEL frames are internally and externally edgebanded. Multi-opening frames are available. Appliance frames with raw inside edges are available.

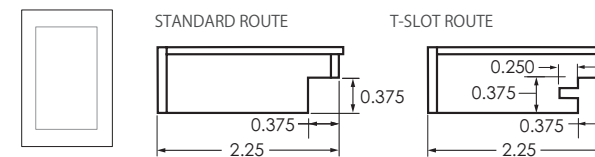

INSERTS AND ACCESSORIES

Clear, frosted, or mirrored glass, and frosted acrylic inserts are available for frame doors. Glass is tempered, and inserts are ordered custom to fit your frames. Allow 10 days in addition to our standard lead time.

Retainer clips and clear retainer strips are available for purchase. See profile for guidelines on determining sizes if you are not ordering an insert from us.

FLOATING SHELVES

Miter folded floating shelves are available in High Gloss Wired materials. Standard height is 2"; standard depth is 10". Available in 1/16" width increments from 22.5" to 72". Standard grain direction will be horizontal on top, bottom and front edge. Ends will have vertical grain. Option of horizontal grain top, bottom and all edges. Metal brackets are included with your order. Max load weight for included bracket is 10 lbs per lineal foot.

CLEANING AND CARE

FENIX NTM® and TFL surfaces should be cleaned regularly with a Magic Eraser or damp cloth with warm water or mild detergents. Do not use products containing abrasive substances or abrasive sponges. Products with a high acid or very alkaline content should be avoided because they can stain the surface. Avoid furniture polishes and wax based cleaners because they may form a sticky layer making the surface susceptible to dirt and dust. Micro scratches can be healed on the FENIX NTM® product by using a Magic Eraser in a circular motion. The sponge can be dry or slightly damp. The heat created through friction heals the surface.

Acrylic and Wired surfaces should be cleaned with a damp microfiber cloth or wet chamois with mild soap. Never dry-wipe the acrylic finish. Avoid any abrasive cleaners, solvent based cleaners, or harsh chemicals as well as paper towels, brushes or scouring pads. Polish kits are available for purchase.

Northern Contours is not responsible for any damage done by abrasive cleaning products or procedures.

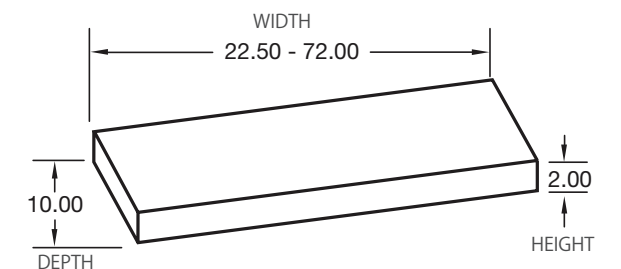

ACCESSORY AVAILABILITY CHART

COLLECTION	LAMINATED SHEETS				FRAMES	FLOATING SHELVES
	4X8	CTS	NORLAM	PSA		
FENIX NTM®	1/8", 1/4", 1/2", 5/8", 3/4"	1/8", 1/4", 1/2", 5/8", 3/4"	4'x8'	N/A	NERO INGO ONLY	N/A
ACRYLIC	1/8", 1/4", 1/2", 5/8", 3/4"	1/8", 1/4", 1/2", 5/8", 3/4"	4'x8'	4'x8'	YES	N/A
WIRED 2DL	1/8", 1/4", 1/2", 5/8", 3/4"	1/8", 1/4", 1/2", 5/8", 3/4"	4'x8'	4'x8', 4'x10', 4'x12'	YES	YES
TFL	1/4", 3/4"	1/4", 3/4"	N/A	N/A	YES	N/A



LEVEL

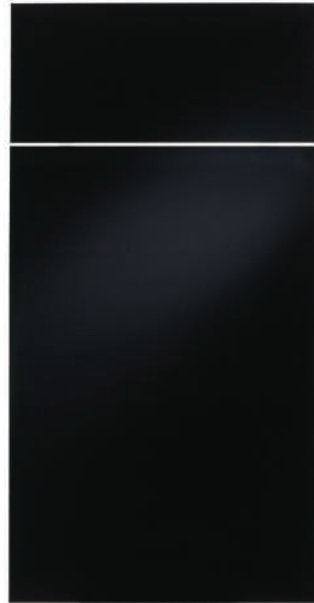

BLACK ACRYLIC

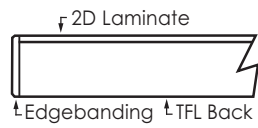

Door | Drawer Front

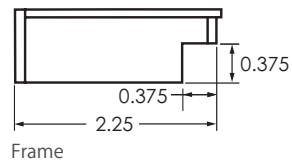

Frame

PROFILE SPECIFICATIONS

DOOR STYLE	Slab
CONSTRUCTION	Flat laminated and externally edgebanded
FACE MATERIAL	FENIX NTM [®] , TFL, High Gloss Acrylic, High Gloss Wired 2DL
EDGEBANDING	Matching or specialty options
BACK MATERIAL	Matching or color coordinated TFL
CORE	3/4" engineered core
GRAIN DIRECTION	Vertical is standard on doors, drawer fronts and frames Horizontal is available, up to 47" in height

ADDITIONAL OPTIONS

ROUTE FOR INSERT	Standard route for insert shown T-slot route available Clear, Frosted, or Mirrored glass, and Frosted Acrylic inserts available
MULTI-PANELS	Not available
FINGERPULLS	Not available
HINGE BORING	See page 3 for standard patterns and placement Custom drilling available
MODIFICATIONS	Stile and rail widths on frames can be altered
PAINT GRADE	Not available

SIZE PARAMETERS

DOORS DRAWER FRONTS	6" x 6" minimum 47" x 95" maximum, warranted to 31" x 60"
OVERLAYS	2.875" x 12" minimum
FRAMES	7" x 7" minimum 30" x 72" maximum
INSERT SIZING	For Standard and T-slot route subtract 3.875" from width and height to determine insert size with 1/16" clearance on all sides



LEVEL | WHITE ACRYLIC

FACE | EDGE BANDING | BACKER AVAILABILITY CHART

M = Matching, 2P = 2-Part, 3D = 3D Aluminum, BR = Brushed Steel

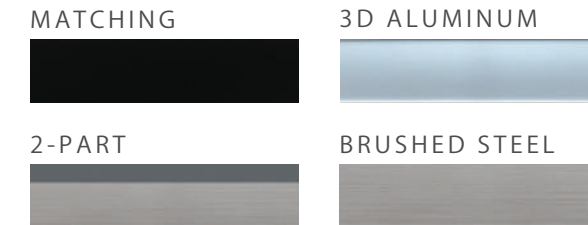

ID	NAME	EDGE BANDING				BACK
		M	2P	3D	BR	
FENIX NTM [®]						STANDARD TFL or FENIX NTM [®] (UPCHARGE)
15500	Bianco Kos	•		•	•	White TFL
15503	Nero Ingo	•		•	•	Black TFL
TFL						TFL
20009	Gibraltar	•		•	•	Gibraltar
20010	Palomino	•		•	•	Palomino
20011	Nizza	•		•	•	Nizza
20012	White 100	•		•	•	White 100
HIGH GLOSS ACRYLIC						STANDARD TFL or ACRYLIC (UPCHARGE)
15001	Black Acrylic	•		•	•	Black TFL
15000	Dark Grey Acrylic	•	•	•	•	Storm TFL
15011	Metallic Graphite Acrylic	•		•	•	Slate TFL
15020	Mirage Acrylic	•		•	•	White TFL
15015	Smoke Acrylic	•		•	•	Folkstone Grey TFL
15005	White Acrylic	•	•	•	•	White TFL
WIRED 2DL						STANDARD TFL
15006	Wired Bronze	•		•	•	Slate TFL
15008	Wired Cobalt	•		•	•	Brittany Blue TFL
15009	Wired Mercury	•		•	•	Storm TFL
15030	Wired White	•	•	•	•	White TFL
15023	Wired Zinc	•		•	•	Black TFL



LEVEL SHAKER

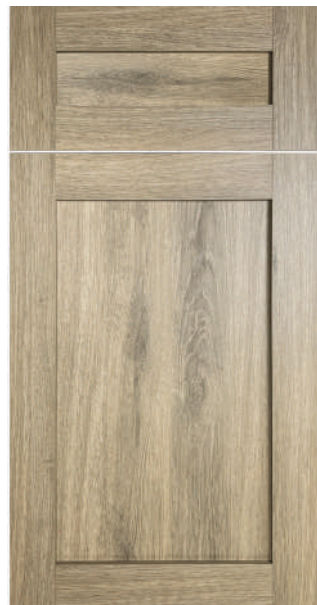

PALOMINO

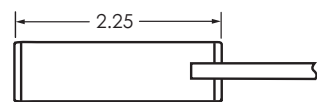

Door | Drawer Front

PROFILE SPECIFICATIONS

DOOR STYLE	Square
CONSTRUCTION	5-Piece Shaker TFL stiles and rails TFL insert panel
FACE MATERIAL	Colors shown below
EDGE BANDING	Matching
BACK MATERIAL	Matching
CORE	3/4" engineered core
GRAIN DIRECTION	Vertical grain is standard on door insert panels Horizontal grain is standard on drawer front insert panels

ADDITIONAL OPTIONS

MULTI-PANELS	Not available
FINGERPULLS	Not available
HINGE BORING	See page 3 for standard patterns and placement Custom drilling available
MODIFICATIONS	Not available

SIZE PARAMETERS

DOORS DRAWER FRONTS	7.6" x 6" minimum 37" x 96" maximum, warranted to 31" x 60"
SLAB DRAWER FRONTS	6" x 6" minimum
OVERLAYS	2.875" x 12" minimum

MATERIALS

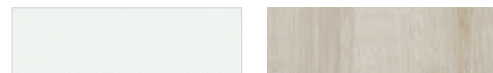

White 100

Nizza



Palomino

Gibraltar



LEVEL SHAKER | PALOMINO

3

5-PIECE profile wrapped doors

5-PIECE PROFILE WRAPPED DOORS

5-Piece doors are available in Shaker or Traditional Miter styles. Profile wrapped stiles and rails assure a uniform appearance on the face and back of components. True grain orientation on rails provides a more realistic appearance.

CLEANING AND CARE

Clean using mild soap and a damp cotton cloth, mild kitchen or glass cleaning products or denatured alcohol. Bleach (a 2% mixture) can be used as a disinfectant on most surfaces. Test on a non-visual spot before using. Avoid any abrasive materials, solvent based cleaners, harsh chemicals or any brushes or scouring pads. **DO NOT USE ACETONE.**

HEAT RESISTANCE

The KCMA standard for heat resistance requires that doors withstand 24 hours at 120°F (49°C) and 70% humidity without showing discoloration, blistering or other material failure. All Northern Contours doors and drawer fronts exceed this standard. Our average heat resistance is 185°F (85°C); the range is 175°F–210°F (79°C–99°C).

Whenever possible, put some distance between heat sources and components. When broiling or using the oven's self-cleaning cycle, open the doors and drawers adjacent to the oven. It is highly recommended to install a filler or heat shield between the cabinet door and the oven, especially when this distance is less than 3/4".

INSERTS AND ACCESSORIES

Clear, frosted, or mirrored glass, and frosted acrylic inserts are available for frame doors. Glass is tempered, and inserts are ordered custom to fit your frames. Allow 10 days in addition to our standard lead time.

Retainer clips and clear retainer strips are available for purchase. See profile for guidelines on determining sizes if you are not ordering an insert from us.

ACCESSORIES

See 3D Laminates section for accessories and components available in matching materials.

HEAT SHIELDS

Heat shields are an excellent product for protecting cabinets from possible damage caused by excessive ambient heat (temperatures beyond the ANSI/KCMA standard). Install them on cabinets near self-cleaning ovens, broilers and dishwashers. Heat shields are 1.56" wide by 30" in length and 0.05" thick. They are fabricated from cold rolled steel, finished in a durable White, Almond or Black powder coat, and predrilled for easy installation.

Installation Instructions: Place heat shield against cabinet frame. Heat shield should be even with the front edge of the cabinet doors with countersunk holes towards back of cabinet. Use four #6 flat head wood screws to install each heat shield (screws are not included.)



TM507



NORDIC WHITE SUPERMATTE

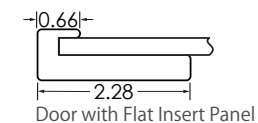

MATERIALS



Nordic White SuperMatte

5-PIECE PROFILE WRAPPED

PROFILE SPECIFICATIONS

PROFILE SPECIFICATIONS

DOOR STYLE	Square
CONSTRUCTION	5-piece Traditional Miter Profile wrapped stiles and rails TFL or laminated insert panel
FACE MATERIAL	Colors shown below
CORE	3/4" engineered core
BACK MATERIAL	Matching
GRAIN DIRECTION	Vertical grain is standard on door insert panels Horizontal grain is standard on drawer front insert panels

ADDITIONAL OPTIONS

MULTI-PANELS	Not available
FINGERPULLS	Not available
HINGE BORING	See page 3 for standard patterns and placement Custom drilling available ▼ Shallow cup hinges recommended
MODIFICATIONS	Not available

SIZE PARAMETERS

DOORS DRAWER FRONTS	7.125" x 5.564" minimum 37" x 96" maximum, warranted to 37" x 60"
SLAB DRAWER FRONTS	3" x 3" minimum
OVERLAYS	2.5" x 6" minimum



TM504



NIZZA

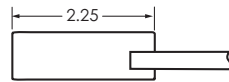

Door with Flat Insert Panel

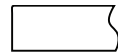

Slab Drawer Front

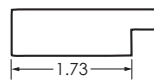

Frame

PROFILE SPECIFICATIONS

DOOR STYLE	Square
CONSTRUCTION	5-piece Traditional Miter Profile wrapped stiles and rails TFL or laminated insert panel
FACE MATERIAL	Colors shown below
CORE	3/4" engineered core
BACK MATERIAL	Matching
GRAIN DIRECTION	Vertical grain is standard on door insert panels Horizontal grain is standard on drawer front insert panels

ADDITIONAL OPTIONS

ROUTE FOR INSERT	Standard route for insert shown T-slot route available Clear, Frosted, or Mirrored glass, and Frosted Acrylic inserts available
MULTI-PANELS	Not available
FINGERPULLS	Not available
HINGE BORING	See page 3 for standard patterns and placement Custom drilling available
MODIFICATIONS	Not available

SIZE PARAMETERS

DOORS DRAWER FRONTS	5.5" x 5.5" minimum 37" x 96" maximum, warranted to 37" x 60"
SLAB DRAWER FRONTS	3" x 3" minimum
OVERLAYS	2.5" x 6" minimum
FRAMES	5.5" x 5.5" minimum 37" x 96" maximum, warranted to 37" x 60"
INSERT SIZING	For Standard and T-slot route subtract 3.577" from width and height to determine insert size with 1/16" clearance on all sides

MATERIALS

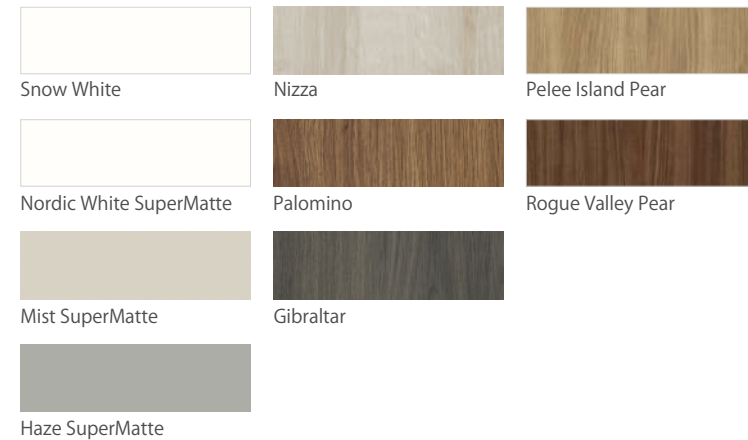

TM506



CHAMELEON

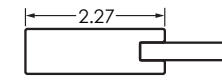

Door with Flat Insert Panel

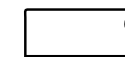

Slab Drawer Front

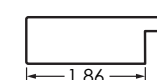

Frame

PROFILE SPECIFICATIONS

DOOR STYLE	Square
CONSTRUCTION	5-piece Traditional Miter Profile wrapped stiles and rails TFL or laminated insert panel
FACE MATERIAL	Colors shown below
CORE	3/4" engineered core
BACK MATERIAL	Matching
GRAIN DIRECTION	Vertical grain is standard on door insert panels Horizontal grain is standard on drawer front insert panels

ADDITIONAL OPTIONS

ROUTE FOR INSERT	Standard route for insert shown T-slot route available Clear, Frosted, or Mirrored glass, and Frosted Acrylic inserts available
MULTI-PANELS	Not available
FINGERPULLS	Not available
HINGE BORING	See page 3 for standard patterns and placement Custom drilling available
MODIFICATIONS	Not available

SIZE PARAMETERS

DOORS DRAWER FRONTS	5.5" x 5.5" minimum 37" x 96" maximum, warranted to 37" x 60"
SLAB DRAWER FRONTS	3" x 3" minimum
OVERLAYS	2.5" x 6" minimum
FRAMES	5.5" x 5.5" minimum 37" x 96" maximum, warranted to 37" x 60"
INSERT SIZING	For Standard and T-slot route subtract 3.841" from width and height to determine insert size with 1/16" clearance on all sides

MATERIALS

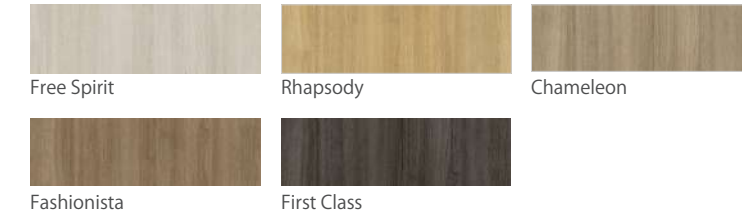



SH504

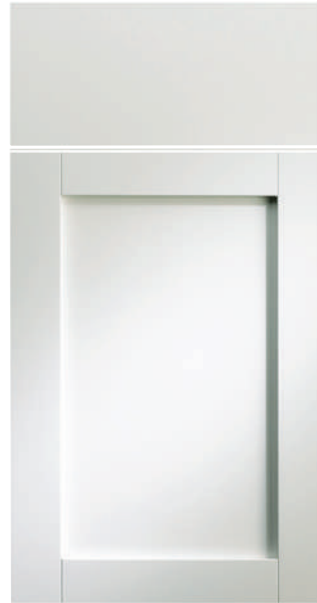

SNOW WHITE

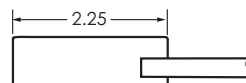

Door with Flat Insert Panel



Slab Drawer Front

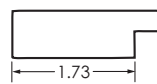

Frame

MATERIALS

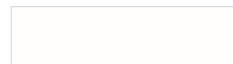

Snow White



Nizza

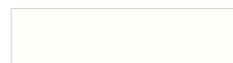

Nordic White SuperMatte

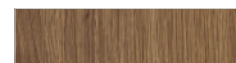

Palomino

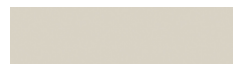

Mist SuperMatte

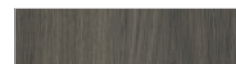

Gibraltar



Haze SuperMatte

PROFILE SPECIFICATIONS

DOOR STYLE	Square
CONSTRUCTION	5-piece Shaker Profile wrapped stiles and rails TFL or laminated insert panel
FACE MATERIAL	Colors shown below
CORE	3/4" engineered core
BACK MATERIAL	Matching
GRAIN DIRECTION	Vertical grain is standard on door insert panels Horizontal grain is standard on drawer front insert panels

ADDITIONAL OPTIONS

ROUTE FOR INSERT	Standard route for insert shown T-slot route available Clear, Frosted, or Mirrored glass, and Frosted Acrylic inserts available
MULTI-PANELS	Not available
FINGERPULLS	Not available
HINGE BORING	See page 3 for standard patterns and placement Custom drilling available
MODIFICATIONS	Not available

SIZE PARAMETERS

DOORS DRAWER FRONTS	7.6" x 6" minimum 37" x 96" maximum, warranted to 37" x 60"
SLAB DRAWER FRONTS	3" x 3" minimum
OVERLAYS	2.5" x 6" minimum
FRAMES	7.6" x 6" minimum 37" x 96" maximum, warranted to 37" x 60"
INSERT SIZING	For Standard and T-slot route subtract 3.577" from width and height to determine insert size with 1/16" clearance on all sides

SH506



FREE SPIRIT

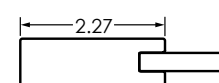

Door with Flat Insert Panel

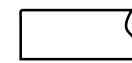

Slab Drawer Front

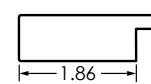

Frame

MATERIALS



Free Spirit

PROFILE SPECIFICATIONS

DOOR STYLE	Square
CONSTRUCTION	5-piece Shaker Profile wrapped stiles and rails TFL or laminated insert panel
FACE MATERIAL	Colors shown below
CORE	3/4" engineered core
BACK MATERIAL	Matching
GRAIN DIRECTION	Vertical grain is standard on door insert panels Horizontal grain is standard on drawer front insert panels

ADDITIONAL OPTIONS

ROUTE FOR INSERT	Standard route for insert shown T-slot route available Clear, Frosted, or Mirrored glass, and Frosted Acrylic inserts available
MULTI-PANELS	Not available
FINGERPULLS	Not available
HINGE BORING	See page 3 for standard patterns and placement Custom drilling available
MODIFICATIONS	Not available

SIZE PARAMETERS

DOORS DRAWER FRONTS	7.6" x 6" minimum 37" x 96" maximum, warranted to 37" x 60"
SLAB DRAWER FRONTS	3" x 3" minimum
OVERLAYS	2.5" x 6" minimum
FRAMES	7.6" x 6" minimum 37" x 96" maximum, warranted to 37" x 60"
INSERT SIZING	For Standard and T-slot route subtract 3.841" from width and height to determine insert size with 1/16" clearance on all sides



TM403



GIBRALTAR

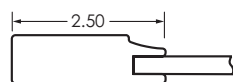

Door with Flat Insert Panel



Slab Drawer Front

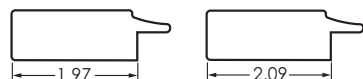

Frame

Frame | Love at First Sight

PROFILE SPECIFICATIONS

DOOR STYLE	Square
CONSTRUCTION	5-piece Traditional Miter Profile wrapped stiles and rails TFL or laminated insert panel
FACE MATERIAL	Colors shown below
CORE	3/4" engineered core
BACK MATERIAL	Matching
GRAIN DIRECTION	Vertical grain is standard on door insert panels Horizontal grain is standard on drawer front insert panels

ADDITIONAL OPTIONS

ROUTE FOR INSERT	Standard route for insert shown T-slot route available Clear, Frosted, or Mirrored glass, and Frosted Acrylic inserts available
MULTI-PANELS	Not available
FINGERPULLS	Not available
HINGE BORING	See page 3 for standard patterns and placement Custom drilling available
MODIFICATIONS	Not available

SIZE PARAMETERS

DOORS DRAWER FRONTS	6" x 6" minimum 37" x 96" maximum, warranted to 37" x 60"
SLAB DRAWER FRONTS	3" x 3" minimum
OVERLAYS	2.5" x 6" minimum
FRAMES	6" x 6" minimum 37" x 96" maximum, warranted to 37" x 60"
INSERT SIZING	For Standard and T-slot route subtract 4.065" from width and height to determine insert size with 1/16" clearance on all sides (For Love at First Sight subtract 4.307" from width and height)

MATERIALS

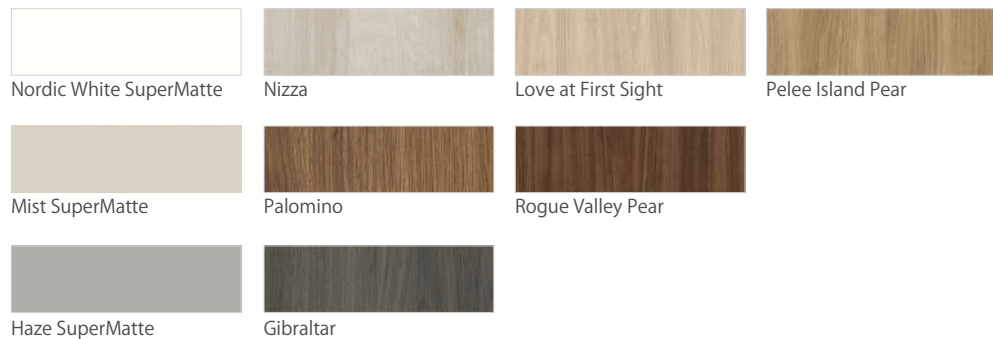

TM405



FASHIONISTA

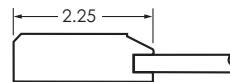

Door with Flat Insert Panel



Slab Drawer Front

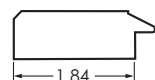

Frame

PROFILE SPECIFICATIONS

DOOR STYLE	Square
CONSTRUCTION	5-piece Traditional Miter Profile wrapped stiles and rails TFL or laminated insert panel
FACE MATERIAL	Colors shown below
CORE	3/4" engineered core
BACK MATERIAL	Matching
GRAIN DIRECTION	Vertical grain is standard on door insert panels Horizontal grain is standard on drawer front insert panels

ADDITIONAL OPTIONS

ROUTE FOR INSERT	Standard route for insert shown T-slot route available Clear, Frosted, or Mirrored glass, and Frosted Acrylic inserts available
MULTI-PANELS	Not available
FINGERPULLS	Not available
HINGE BORING	See page 3 for standard patterns and placement Custom drilling available
MODIFICATIONS	Not available

SIZE PARAMETERS

DOORS DRAWER FRONTS	5.5" x 5.5" minimum 37" x 96" maximum, warranted to 37" x 60"
SLAB DRAWER FRONTS	3" x 3" minimum
OVERLAYS	2.5" x 6" minimum
FRAMES	5.5" x 5.5" minimum 37" x 96" maximum, warranted to 37" x 60"
INSERT SIZING	For Standard and T-slot route subtract 3.805" from width and height to determine insert size with 1/16" clearance on all sides

MATERIALS

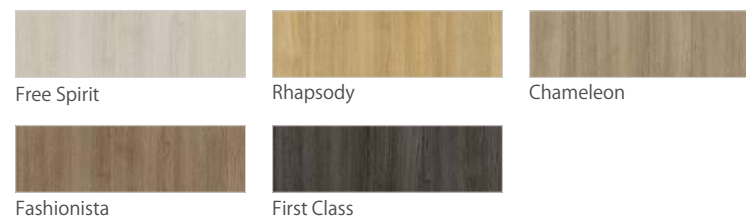



Legacy Profiles represent a collection of classic profiles, echoing the craftsmanship of the past. These profiles are still available to order; however, we encourage you to design your new projects with the more current profiles presented in the rest of this Product Guide.

TM500



SNOW WHITE

Door | Drawer Front

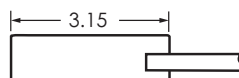

MATERIALS

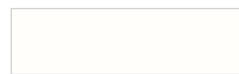

Snow White

SH500



SNOW WHITE

Door | Drawer Front

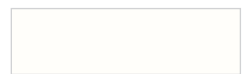
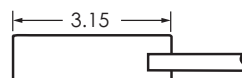

Snow White

TM502



RUSTIC LIGHT OAK

Door | Drawer Front

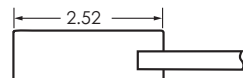

Rustic Light Oak



Weathered Grey Oak

SH502



WEATHERED GREY OAK

Door | Drawer Front

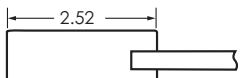

Rustic Light Oak



Weathered Grey Oak

ALTERNATE PANEL OPTION

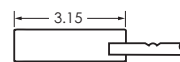

Door with Beaded Insert Panel



Door and Drawer with Beaded Insert Panel



TM403 | HAZE SUPERMATTE

4

3D laminates

3D LAMINATE SPECIFICATIONS

Our 3D Laminate (3DL) selection includes a variety of solids, woodgrains, abstracts, textures and glosses. 3DL is made from PVC, one of the most versatile polymers, and has consistent color, finish and surface quality from edge to edge.

We source our film from highly regarded manufacturers and test each incoming lot for color and gloss consistency. We also contract with an independent research and development group that tests the physical properties of our laminates, including scratch and mar, impact and stain resistance.

Profile detail is routed into the core and then covered with material. This process allows a seamless joint between the face and sides of doors and drawer fronts.

A protective peel coat is applied to specialty materials. Do not expose to direct sunlight before removal. Remove promptly after cabinet installation but prior to decorative hardware. Use fingernail to remove, not sharp objects. Avoid sliding the panels on the outer surface.

BOARD SPECIFICATIONS

Components are made with a high quality, double refined, CARB Phase 2 ATCM 93120 compliant, 3/4" engineered core. An engineered core provides a stable, consistent substrate. Component backs are thermally fused laminate (TFL) and come in a variety of color or woodgrain options. 3/4" Ultra Low Emitting Formaldehyde (ULEF) core with a White TFL back option is available on select door styles by request. 3DL Horizontal Surfaces are produced using 1" and 3/4" engineered core.

NEXUS SERIES

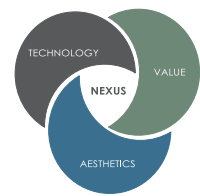

We've harnessed cutting-edge robotic sanding technology to create a smooth, cost-effective alternative to our standard insert panel doors. Nexus robotically sanded components are available at a lower price for all flat panel Shaker profiles. Look for the Nexus icon on the following door profile pages.

CLEANING AND CARE

Clean using mild soap and a damp cotton cloth, mild kitchen or glass cleaning products or denatured alcohol. Bleach (a 2% mixture) can be used as a disinfectant on most surfaces. Test on a non-visible spot before using. Avoid any abrasive materials, solvent based cleaners, harsh chemicals or any brushes or scouring pads. DO NOT USE ACETONE.

DOOR STYLES

Doors can be ordered in the following styles. See profile specifications for options.

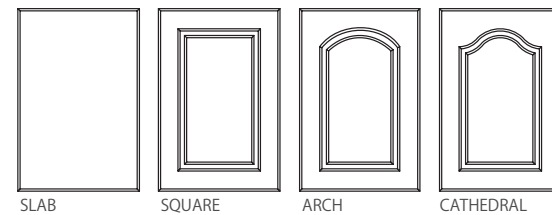

OUTSIDE PROFILES

Outside profiles can be ordered as slab doors or as a modification to the outside profile on any named door style except for Shaker Slim, Manchester II, and Manchester III. *B099 not recommended for all materials. Thinning or effacing may occur on the corners. Material thickness, color, in-use application and lighting are considerations.

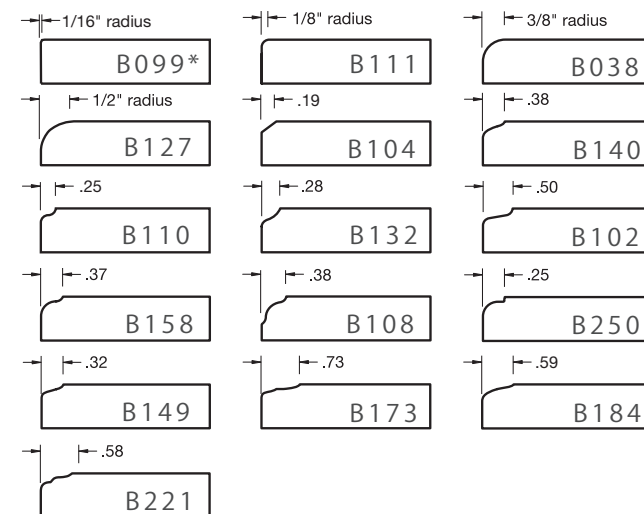

DRAWER FRONTS

Drawer front height and style will determine options for full rail, reduced rail and/or slab fronts. Size minimums can be found on each profile specification page.

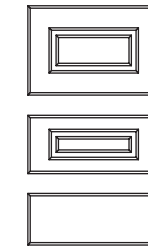

If the height is equal to or greater than the dimensions listed under minimum, fronts will have standard rail dimensions.

If the height is less than the listed minimum and equal to or greater than the reduced rail minimum, fronts will have a 1" center panel and floating rails. Heights under the minimum for reduced rails will be slab.

FRAMES AND MULLIONS

A variety of frame and mullion styles are available. The routed portion of frame and mullion backs can be painted in a coordinating color for an additional charge. Mullion doors in heights from 10.875" - 24" will have 4 lites, 24" - 31" will have 6 lites, 31" - 41" will have 8 lites, and 41" - 60" will have 10 lites.

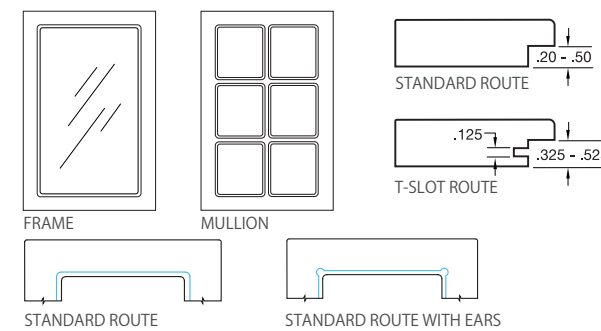

INSERTS AND ACCESSORIES

Clear, frosted, or mirrored glass, and frosted acrylic inserts are available for frame and mullion doors. T-slot route, retainer strip, and paint backs are included with insert orders. Glass is tempered, and inserts are ordered custom to fit your frames and mullions. Allow 10 days in addition to our standard lead time.

Retainer clips and clear retainer strips are available for purchase. See profile for guidelines on determining sizes if you are not ordering an insert from us.

FINGERPULLS

The standard placement for fingerpulls on doors is top AND bottom; on drawer fronts, standard placement is top OR bottom. Fingerpulls are available for all styles excluding: Manchester II, Manchester III, Shaker Slim, Reeded Slim, and Select Series with outside profiles B038, B108 and B127. Fingerpulls are not available with high gloss materials.

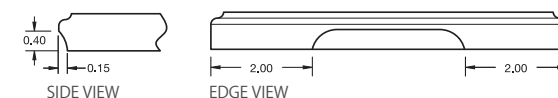

GLAZE

Trained craftsman manually apply the glazed finish on 3DL product. Due to this manual finishing, the buildup of glaze may vary from one part to another. This variance is considered an acceptable characteristic of glazed finishing, parts will not be replaced due to these variations.



We offer Charcoal, Walnut, and White glaze color options on select 3DL materials. Those materials are noted on our material cross reference chart. Look for the glaze option on the following door profile pages.

LAZY SUSAN DOORS

Doors for lazy susans are typically profiled on 3 sides to match other doors with a square profile on the 4th, long side. To specify this, indicate "TBL (top, bottom, left) or TBR (top, bottom, right)" when placing your order. This instructs us to profile the top, bottom and left or right, leaving the other long side square. Not available on Manchester II or Manchester III.

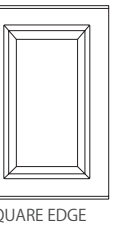

FILLERS AND OVERLAYS

Fillers and overlays are available in fluted or slab styles. Standard flutes start and stop 1" from each end with one flute per width-inch. Minimum width is 2 1/2"; maximum length is 96". Minimum with Rosettes is 3". Fillers have B099 edge detail.

Overlays will be profiled on all four edges to match doors unless otherwise specified. If square edge is required, order a cut-to-size panel (edges will be raw). Fillers and overlays are available with any of the rosette styles we offer. Fluted fillers and overlays are available with glaze on select 3DLs.

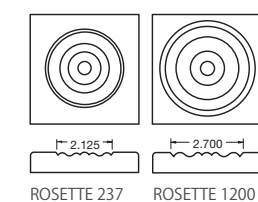
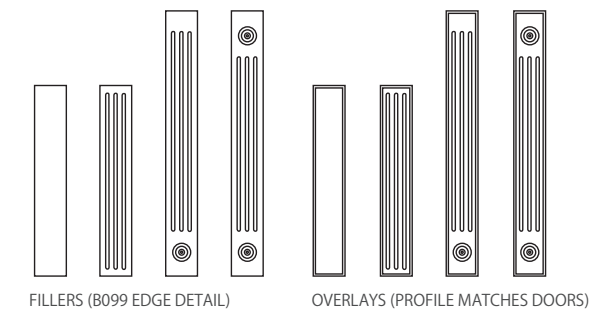

ROSETTES

Rosettes may be added to fillers or ordered individually. All rosettes are 3" x 3", manufactured on 3/4" engineered core. Rosettes are available with glaze on select 3DLs.



MOULDINGS

Mouldings in a variety of styles are available in all 3DL colors in 8' lengths. *Marked mouldings are available with glaze on select 3DLs.

TOP MOUNT CROWNS

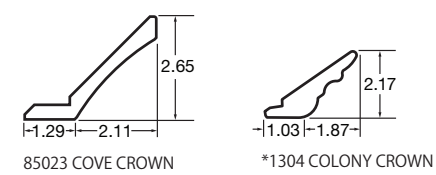
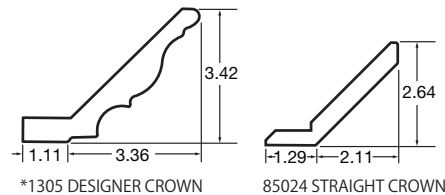

FACE MOUNT CROWNS

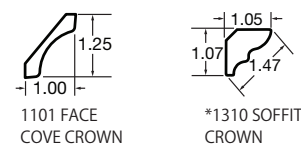
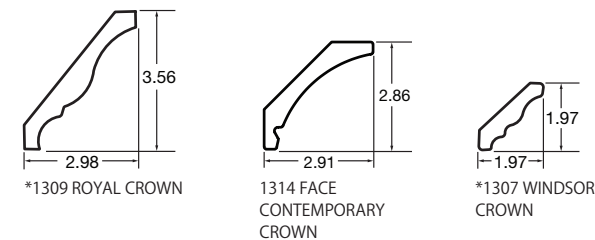

FINISH AND TRIM MOULDING

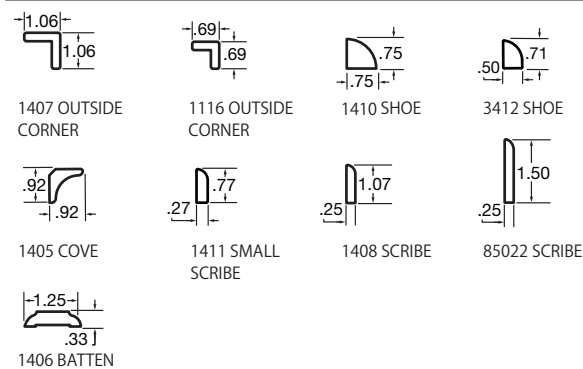

BASE MOULDING

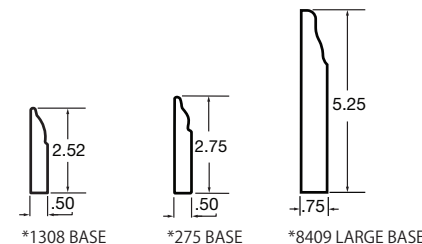

APPLIANCE PANELS



SHAKER INSET | SURF SUPERMATTE

Appliance panels are available for your refrigerators and dishwasher. Please check your appliance specifications on sizes, critical dimensions, panel thickness, etc. before ordering.

MULTI-PANELS

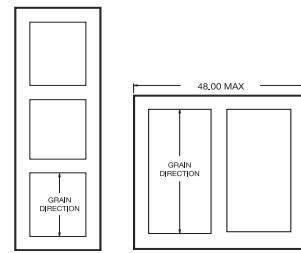

Multi-panel products can be produced in vertical or horizontal configurations for a variety of applications including tall cabinets, islands and peninsula backs. Maximum width for multi-panels with vertical grain direction is 48". Standard configuration will

center the panel between all stiles and rails. Multi-panels are not available on Manchester II, Manchester III or slab door styles.

VALANCES

Valances are available in custom sizes and three styles. The minimum width is 24", maximum is 96". Top and sides will have B099 edge detail, bottom will be profiled to match doors and drawer fronts unless otherwise specified. Horizontal grain is standard. If vertical grain is specified, maximum width is 48".

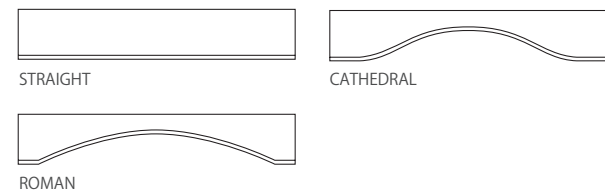

LIGHT RAIL MITERFOLD

A 2" x 2" L-Shaped Miter Fold Light Rail is available. This decorative piece is typically used under a cabinet and can hide a light strip.



WINE RACKS

Scalloped and grid wine racks are available in custom sizes and are sold as two-piece sets with each piece ordered individually. Wine racks have B099 outside edges. For scalloped style, minimum shoulder width is 1". The scallop is 3 1/2" and the space between scallops is 1/2". For grid style, opening is 3 1/4" x 3 1/4". Maximum width for either style is 46" with woodgrain running vertically.

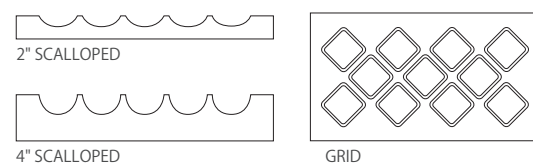

FLOATING SHELVES

Miter folded, floating shelves are available in all 3DL materials. Standard height is 2"; standard depth is 10". Available in 1/16" width increments from 22.5" to 72". Standard grain direction will be horizontal on top, bottom and front edge. Ends will have vertical grain. Option of horizontal grain top, bottom and all edges. Metal brackets are included with your order. Max load weight for included bracket is 10 lbs per lineal foot.

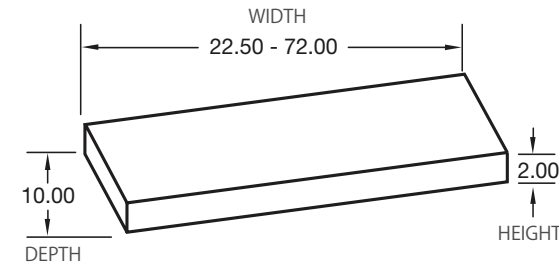

CORNER AND END SHELVES

Shelves are available on a 3/4" engineered core with TFL back. Matching backs are available on select materials. Corner shelf width and depth are always equal, radius is determined by width. End shelves are available in Left End or Right End configurations. Default corner radius is 3", unless otherwise specified, and can be equal to or smaller than the shortest leg. Primary profiles are available with any outside profile shown on page 18. Secondary profile is B099. Minimum width is 6", maximum is 24".

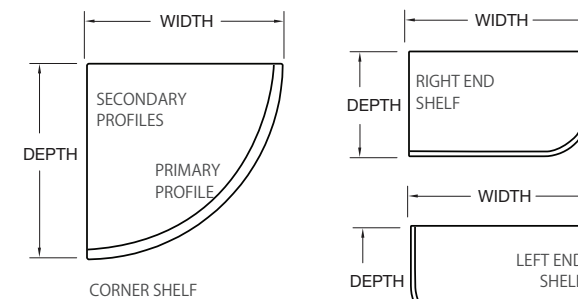

MICROWAVE SHELVES

Shelves are available on a 3/4" engineered core with TFL back. Matching backs are available on select materials. Microwave shelves have 1" radius corners on the front corners. Minimum width is 6", maximum is 24".

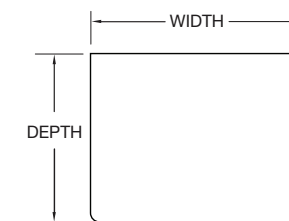

CUT-TO-SIZE PANELS



Available in 1/8", 1/4", 1/2", 5/8" or 3/4" thicknesses. Edges are raw. Single-sided 1/8" and 1/4" sheets will have raw backs. Single-sided 1/2", 5/8" and 3/4" sheets will have White TFL backs, unless otherwise specified. Two-sided sheets in all thicknesses will have matching 3DL backs. Vertical grain direction is standard.

SHEET STOCK

Available in 4' x 8' sheets in 1/8", 1/4", 1/2", 5/8" or 3/4" thicknesses. Single-sided 1/8" and 1/4" sheets will have raw backs. Single-sided 1/2", 5/8" and 3/4" sheets will have White TFL backs, unless otherwise specified. Two-sided sheets in all thicknesses will have matching 3DL backs. Vertical grain direction is standard.

BEADBOARD - BEAD, FLUTE & REED

Available in 1/4" thickness in full sheets (4' x 8') or half sheets (4' x 4' or 2' x 8'). Available in all 3DL selections except high gloss. Glaze is available on select materials. Back and edges are raw. Vertical grain direction is standard.



NORLAM



3DL applied to a semi-rigid backer that can be applied with contact adhesive. Vertical grain direction is standard. Available in 4' x 8' sheets. Finished thickness is 1/32".

PRESSURE SENSITIVE ADHESIVE (PSA)



3DL with a pressure sensitive adhesive developed specifically for cabinet refacing applications. Vertical grain direction is standard. Available in 4' x 8', 4' x 10', or 4' x 12' sheets. 4' x 8' sheets can be cut into two 2' x 8' at no charge or cut into 2" or 3.5" strips for a fee.

NORLAM WITH PSA



3DL applied to a semi-rigid backer and a pressure sensitive adhesive. Benefits of a more rigid backer and ease of application. Vertical grain direction is standard. Available in 4' x 8' sheets.

RAW 3DL

Raw 3DL is available by the lineal foot, measuring a minimum of 52" in usable width. We recommend testing a small sample with your choice of adhesive before proceeding.



ELEGANTE II
STRATUS SUPERMATTE + GAUNTLET SUPERMATTE



SHAKER
STRATUS SUPERMATTE + MIDNIGHT SUPERMATTE



ELEGANTE II
SUPER REAL WALNUT + ONYX SUPERMATTE



ELEGANTE II



SUPER REAL WALNUT

Door | Drawer Front

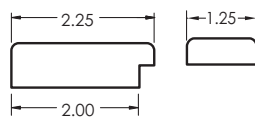
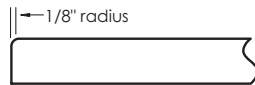

Frame | Mullion

PROFILE SPECIFICATIONS

DOOR STYLE	Slab
CONSTRUCTION	Slight radius edges Membrane pressed face and sides
FACE MATERIAL	All 3DL color selections
CORE	3/4" engineered core 3/4" ULEF core with White TFL back available
BACK MATERIAL	Standard back is White TFL Off-White, Grey, Black or Neutral Maple TFL available at no additional charge Matching back TFL available with select 3DLs for an additional charge
GRAIN DIRECTION	Vertical grain is standard on doors, frames and mullions Horizontal is available, up to 48" in height Horizontal grain is standard on drawer fronts

ADDITIONAL OPTIONS

ROUTE FOR INSERT	Standard frame and mullion route for insert shown T-slot route available Clear, Frosted, or Mirrored glass, and Frosted Acrylic inserts available
FINGERPULLS	Standard or custom placement available Not available with high gloss materials
HINGE BORING	See page 3 for standard patterns and placement Custom drilling available
MODIFICATIONS	Stile and rail widths on frames and mullions can be altered

SIZE PARAMETERS

DOORS DRAWER FRONTS	3" x 3" minimum 48" x 96" maximum, warranted to 31" x 60"
OVERLAYS	2.5" x 6" minimum
FRAMES	7" x 7" minimum 31" x 60" maximum
MULLIONS	10.75" x 10.75" minimum 31" x 60" maximum
MULLION LITES	10.75" to 24" heights = 4 lites 24" to 31" heights = 6 lites 31" to 41" heights = 8 lites 41" to 60" heights = 10 lites
INSERT SIZING	For Standard route subtract 4.125" from width and height to determine insert size with 1/16" clearance on all sides For T-slot route subtract 3.625" from width and height to determine insert size with 1/16" clearance on all sides

ITALIA II



KISS CURL

Door | Drawer Front

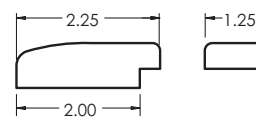
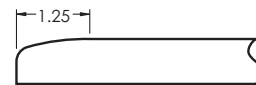

Frame | Mullion

PROFILE SPECIFICATIONS

DOOR STYLE	Slab
CONSTRUCTION	Pillow edges Membrane pressed face and sides
FACE MATERIAL	All 3DL color selections
CORE	3/4" engineered core 3/4" ULEF core with White TFL back available
BACK MATERIAL	Standard back is White TFL Off-White, Grey, Black or Neutral Maple TFL available at no additional charge Matching back TFL available with select 3DLs for an additional charge
GRAIN DIRECTION	Vertical grain is standard on doors, frames and mullions Horizontal is available, up to 48" in height Horizontal grain is standard on drawer fronts

ADDITIONAL OPTIONS

ROUTE FOR INSERT	Standard frame and mullion route for insert shown T-slot route available Clear, Frosted, or Mirrored glass, and Frosted Acrylic inserts available
FINGERPULLS	Standard or custom placement available Not available with high gloss materials
HINGE BORING	See page 3 for standard patterns and placement Custom drilling available
MODIFICATIONS	Stile and rail widths on frames and mullions can be altered

SIZE PARAMETERS

DOORS DRAWER FRONTS	3.1" x 3.1" minimum 48" x 96" maximum, warranted to 31" x 60"
OVERLAYS	2.5" x 6" minimum
FRAMES	7" x 7" minimum 31" x 60" maximum
MULLIONS	10.75" x 10.75" minimum 31" x 60" maximum
MULLION LITES	10.75" to 24" heights = 4 lites 24" to 31" heights = 6 lites 31" to 41" heights = 8 lites 41" to 60" heights = 10 lites
INSERT SIZING	For Standard route subtract 4.125" from width and height to determine insert size with 1/16" clearance on all sides For T-slot route subtract 3.625" from width and height to determine insert size with 1/16" clearance on all sides



DIAMOND



RHAPSODY

Door | Drawer Front

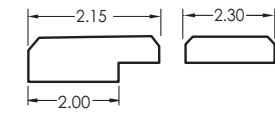

Frame | Mullion

PROFILE SPECIFICATIONS

DOOR STYLE	Slab
CONSTRUCTION	Beveled edges Membrane pressed face and sides
FACE MATERIAL	All 3DL color selections
CORE	3/4" engineered core 3/4" ULEF core with White TFL back available
BACK MATERIAL	Standard back is White TFL Off-White, Grey, Black or Neutral Maple TFL available at no additional charge Matching back TFL available with select 3DLs for an additional charge
GRAIN DIRECTION	Vertical grain is standard on doors, frames and mullions Horizontal is available, up to 48" in height Horizontal grain is standard on drawer fronts

ADDITIONAL OPTIONS

ROUTE FOR INSERT	Standard frame and mullion route for insert shown T-slot route available Clear, Frosted, or Mirrored glass, and Frosted Acrylic inserts available
FINGERPULLS	Standard or custom placement available Not available with high gloss materials
HINGE BORING	See page 3 for standard patterns and placement Custom drilling available
MODIFICATIONS	Stile and rail widths on frames and mullions can be altered

SIZE PARAMETERS

DOORS DRAWER FRONTS	3" x 3" minimum 48" x 96" maximum, warranted to 31" x 60"
OVERLAYS	2.5" x 6" minimum
FRAMES	7" x 7" minimum 31" x 60" maximum
MULLIONS	10.75" x 10.75" minimum 31" x 60" maximum
MULLION LITES	10.75" to 24" heights = 4 lites 24" to 31" heights = 6 lites 31" to 41" heights = 8 lites 41" to 60" heights = 10 lites
INSERT SIZING	For Standard route subtract 4.125" from width and height to determine insert size with 1/16" clearance on all sides For T-slot route subtract 3.625" from width and height to determine insert size with 1/16" clearance on all sides

NOVARA



SALT OF THE EARTH

Door | Drawer Front

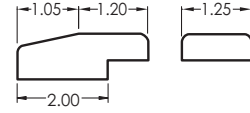
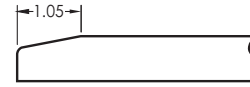

Frame | Mullion

PROFILE SPECIFICATIONS

DOOR STYLE	Slab
CONSTRUCTION	Beveled edges Membrane pressed face and sides
FACE MATERIAL	All 3DL color selections
CORE	3/4" engineered core 3/4" ULEF core with White TFL back available
BACK MATERIAL	Standard back is White TFL Off-White, Grey, Black or Neutral Maple TFL available at no additional charge Matching back TFL available with select 3DLs for an additional charge
GRAIN DIRECTION	Vertical grain is standard on doors, frames and mullions Horizontal is available, up to 48" in height Horizontal grain is standard on drawer fronts

ADDITIONAL OPTIONS

ROUTE FOR INSERT	Standard frame and mullion route for insert shown T-slot route available Clear, Frosted, or Mirrored glass, and Frosted Acrylic inserts available
FINGERPULLS	Standard or custom placement available Not available with high gloss materials
HINGE BORING	See page 3 for standard patterns and placement Custom drilling available
MODIFICATIONS	Stile and rail widths on frames and mullions can be altered

SIZE PARAMETERS

DOORS DRAWER FRONTS	3.1" x 3.1" minimum 48" x 96" maximum, warranted to 31" x 60"
OVERLAYS	2.5" x 6" minimum
FRAMES	7" x 7" minimum 31" x 60" maximum
MULLIONS	11.35" x 11.35" minimum 31" x 60" maximum
MULLION LITES	11.35" to 24" heights = 4 lites 24" to 31" heights = 6 lites 31" to 41" heights = 8 lites 41" to 60" heights = 10 lites
INSERT SIZING	For Standard route subtract 4.125" from width and height to determine insert size with 1/16" clearance on all sides For T-slot route subtract 3.625" from width and height to determine insert size with 1/16" clearance on all sides



FLUTED



SUPER REAL WALNUT

Door | Drawer Front

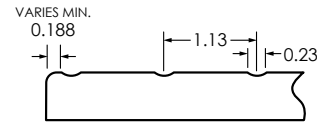

Reeds are centered based on width of the door or drawer front. Spacing at the edges may vary as the width changes. Components of the same width will align with each other.

PROFILE SPECIFICATIONS

DOOR STYLE	Slab with vertical lines
CONSTRUCTION	Membrane pressed face and sides Slight radius edges
FACE MATERIAL	All 3DL color selections, except high gloss
CORE	3/4" engineered core 3/4" ULEF core with White TFL back available
BACK MATERIAL	Standard back is White TFL Off-White, Grey, Black or Neutral Maple TFL available at no additional charge Matching back TFL available with select 3DLs for an additional charge
GRAIN DIRECTION	Vertical grain is standard on doors and drawer fronts Horizontal is available, up to 48" in height

ADDITIONAL OPTIONS

FINGERPULLS	Standard or custom placement available
HINGE BORING	See page 3 for standard patterns and placement Custom drilling available
MODIFICATIONS	Not available

SIZE PARAMETERS

DOORS DRAWER FRONTS	3" x 3" minimum 48" x 96" maximum, warranted to 31" x 60"
OVERLAYS	2.5" x 6" minimum

REEDED



SHEER BEAUTY

Door | Drawer Front

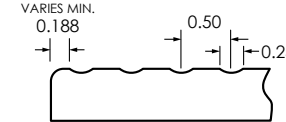

Reeds are centered based on width of the door or drawer front. Spacing at the edges may vary as the width changes. Components of the same width will align with each other.

PROFILE SPECIFICATIONS

DOOR STYLE	Slab with vertical lines
CONSTRUCTION	Membrane pressed face and sides Slight radius edges
FACE MATERIAL	All 3DL color selections, except high gloss
CORE	3/4" engineered core 3/4" ULEF core with White TFL back available
BACK MATERIAL	Standard back is White TFL Off-White, Grey, Black or Neutral Maple TFL available at no additional charge Matching back TFL available with select 3DLs for an additional charge
GRAIN DIRECTION	Vertical grain is standard on doors and drawer fronts Horizontal is available, up to 48" in height

ADDITIONAL OPTIONS

FINGERPULLS	Standard or custom placement available
HINGE BORING	See page 3 for standard patterns and placement Custom drilling available
MODIFICATIONS	Not available

SIZE PARAMETERS

DOORS DRAWER FRONTS	3" x 3" minimum 48" x 96" maximum, warranted to 31" x 60"
OVERLAYS	2.5" x 6" minimum

REEDED SLIM

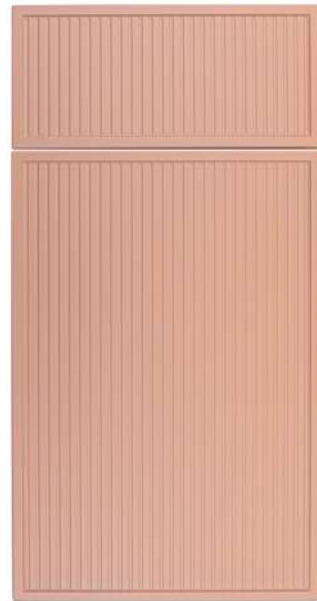

ROJA rPET

Door | Drawer Front

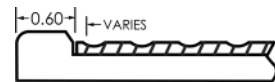

.125 (B111)

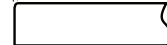

Slab Drawer Front

Reeds are centered based on width of the door or drawer front. Spacing at the edges may vary as the width changes. Components of the same width will align with each other.

PROFILE SPECIFICATIONS

DOOR STYLE	Square
CONSTRUCTION	Routed drop-in panel Membrane pressed face and sides
FACE MATERIAL	All 3DL color selections, except high gloss
CORE	3/4" engineered core 3/4" ULEF core with White TFL back available
BACK MATERIAL	Standard back is White TFL Off-White, Grey, Black or Neutral Maple TFL available at no additional charge Matching back TFL available with select 3DLs for an additional charge
GRAIN DIRECTION	Vertical grain is standard on doors and drawer fronts Horizontal is available, up to 48" in height

ADDITIONAL OPTIONS

MULTI-PANELS	Vertical or horizontal configurations
FINGERPULLS	Not available
HINGE BORING	See page 3 for standard patterns and placement Custom drilling available ▼ Shallow cup hinges recommended
MODIFICATIONS	Stile and rail widths can be altered

SIZE PARAMETERS

DOORS DRAWER FRONTS	3" x 3" minimum 48" x 96" maximum, warranted to 31" x 60"
SLAB DRAWER FRONTS	3" x 3" minimum
OVERLAYS	2.5" x 6" minimum

SHAKER SLIM



OASIS rPET

Door | Drawer Front

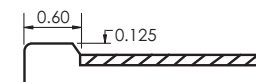

Frame

.125 (B111)



Slab Drawer Front

NEXUS
Robotically sanded, economical alternative to our insert panel shakers

PROFILE SPECIFICATIONS

DOOR STYLE	Square
CONSTRUCTION	Flat drop-in panel Membrane pressed face and sides
FACE MATERIAL	All 3DL color selections High gloss not warranted for warp
CORE	3/4" engineered core 3/4" ULEF core with White TFL back available
BACK MATERIAL	Standard back is White TFL Off-White, Grey, Black or Neutral Maple TFL available at no additional charge Matching back TFL available with select 3DLs for an additional charge
GRAIN DIRECTION	Vertical grain is standard on doors and frames Horizontal is available, up to 48" in height Horizontal grain is standard on drawer fronts

ADDITIONAL OPTIONS

ROUTE FOR INSERT	Standard frame route for insert shown T-slot route available Clear, Frosted, or Mirrored glass, and Frosted Acrylic inserts available
MULTI-PANELS	Vertical or horizontal configurations
FINGERPULLS	Not available
HINGE BORING	See page 3 for standard patterns and placement Custom drilling available ▼ Shallow cup hinges recommended
MODIFICATIONS	Stile and rail widths can be altered

SIZE PARAMETERS

DOORS DRAWER FRONTS	3" x 3" minimum 48" x 96" maximum, warranted to 31" x 60"
SLAB DRAWER FRONTS	3" x 3" minimum
OVERLAYS	2.5" x 6" minimum
FRAMES	7" x 7" minimum 31" x 60 maximum
INSERT SIZING	For Standard route subtract 3.875" from width and height to determine insert size with 1/16" clearance on all sides For T-slot route subtract 3.425" from width and height to determine insert size with 1/16" clearance on all sides



SHAKER

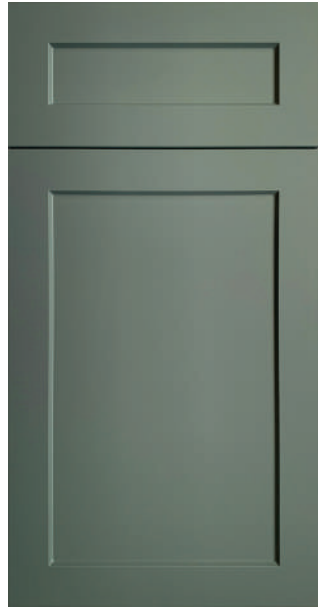

SURF SUPERMATTE

Door | Drawer Front

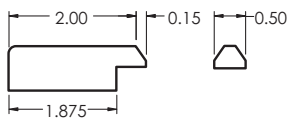
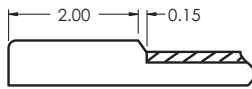

Frame | Mullion

.125 (B111)

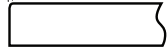

Slab Drawer Front

NEXUS
Robotically sanded, economical alternative to our insert panel shakers

PROFILE SPECIFICATIONS

DOOR STYLE	Square
CONSTRUCTION	Flat drop-in panel Membrane pressed face and sides
FACE MATERIAL	All 3DL color selections High gloss not warranted for warp
CORE	3/4" engineered core 3/4" ULEF core with White TFL back available
BACK MATERIAL	Standard back is White TFL Off-White, Grey, Black or Neutral Maple TFL available at no additional charge Matching back TFL available with select 3DLs for an additional charge
GRAIN DIRECTION	Vertical grain is standard on doors, frames and mullions Horizontal is available, up to 48" in height Horizontal grain is standard on drawer fronts

ADDITIONAL OPTIONS

ROUTE FOR INSERT	Standard frame and mullion route for insert shown T-slot route available Clear, Frosted, or Mirrored glass, and Frosted Acrylic inserts available
MULTI-PANELS	Vertical or horizontal configurations
FINGERPULLS	Standard or custom placement available Not available with high gloss materials
HINGE BORING	See page 3 for standard patterns and placement Custom drilling available
MODIFICATIONS	Stile and rail widths and outside profiles can be altered

SIZE PARAMETERS

DOORS DRAWER FRONTS	5.3" x 5.3" minimum 48" x 96" maximum, warranted to 31" x 60"
REDUCED RAIL DRAWER FRONTS	5.3" x 3" minimum
SLAB DRAWER FRONTS	3" x 3" minimum
OVERLAYS	2.5" x 6" minimum
FRAMES	6.8" x 6.8" minimum 31" x 60" maximum
MULLIONS	9.8" x 9.8" minimum 31" x 60" maximum
MULLION LITES	9.8" to 24" heights = 4 lites 24" to 31" heights = 6 lites 31" to 41" heights = 8 lites 41" to 60" heights = 10 lites
INSERT SIZING	For Standard route subtract 3.875" from width and height to determine insert size with 1/16" clearance on all sides For T-slot route subtract 3.625" from width and height to determine insert size with 1/16" clearance on all sides

SHAKER SHALLOW

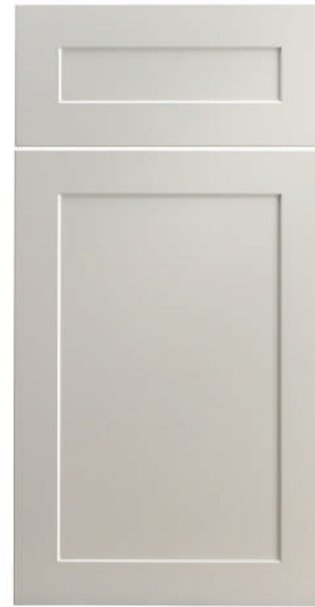

STRATUS SUPERMATTE

Door | Drawer Front

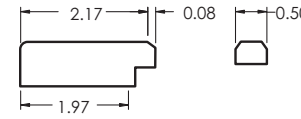
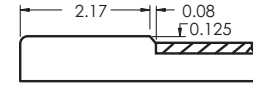

Frame | Mullion

.125 (B111)

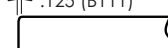

Slab Drawer Front

NEXUS
Robotically sanded, economical alternative to our insert panel shakers

PROFILE SPECIFICATIONS

DOOR STYLE	Square
CONSTRUCTION	Flat drop-in panel Membrane pressed face and sides
FACE MATERIAL	All 3DL color selections High gloss not warranted for warp
CORE	3/4" engineered core 3/4" ULEF core with White TFL back available
BACK MATERIAL	Standard back is White TFL Off-White, Grey, Black or Neutral Maple TFL available at no additional charge Matching back TFL available with select 3DLs for an additional charge
GRAIN DIRECTION	Vertical grain is standard on doors, frames and mullions Horizontal is available, up to 48" in height Horizontal grain is standard on drawer fronts

ADDITIONAL OPTIONS

ROUTE FOR INSERT	Standard frame and mullion route for insert shown T-slot route available Clear, Frosted, or Mirrored glass, and Frosted Acrylic inserts available
MULTI-PANELS	Vertical or horizontal configurations
FINGERPULLS	Standard or custom placement available Not available with high gloss materials
HINGE BORING	See page 3 for standard patterns and placement Custom drilling available
MODIFICATIONS	Stile and rail widths and outside profiles can be altered

SIZE PARAMETERS

DOORS DRAWER FRONTS	5.5" x 5.5" minimum 48" x 96" maximum, warranted to 31" x 60"
REDUCED RAIL DRAWER FRONTS	5.5" x 3" minimum
SLAB DRAWER FRONTS	3" x 3" minimum
OVERLAYS	2.5" x 6" minimum
FRAMES	7" x 7" minimum 31" x 60" maximum
MULLIONS	10" x 10" minimum 31" x 60" maximum
MULLION LITES	10" to 24" heights = 4 lites 24" to 31" heights = 6 lites 31" to 41" heights = 8 lites 41" to 60" heights = 10 lites
INSERT SIZING	For Standard route subtract 4.043" from width and height to determine insert size with 1/16" clearance on all sides For T-slot route subtract 3.593" from width and height to determine insert size with 1/16" clearance on all sides



SHAKER DIAMOND



OASIS rPET

Door | Drawer Front

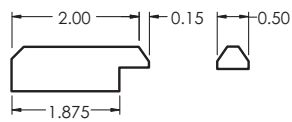
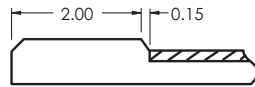

Frame | Mullion

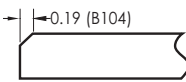

Slab Drawer Front

NEXUS
Robotically sanded, economical alternative to our insert panel shakers

PROFILE SPECIFICATIONS

DOOR STYLE	Square
CONSTRUCTION	Flat drop-in panel Membrane pressed face and sides
FACE MATERIAL	All 3DL color selections High gloss not warranted for warp
CORE	3/4" engineered core 3/4" ULEF core with White TFL back available
BACK MATERIAL	Standard back is White TFL Off-White, Grey, Black or Neutral Maple TFL available at no additional charge Matching back TFL available with select 3DLs for an additional charge
GRAIN DIRECTION	Vertical grain is standard on doors, frames and mullions Horizontal is available, up to 48" in height Horizontal grain is standard on drawer fronts

ADDITIONAL OPTIONS

ROUTE FOR INSERT	Standard frame and mullion route for insert shown T-slot route available Clear, Frosted, or Mirrored glass, and Frosted Acrylic inserts available
MULTI-PANELS	Vertical or horizontal configurations
FINGERPULLS	Standard or custom placement available Not available with high gloss materials
HINGE BORING	See page 3 for standard patterns and placement Custom drilling available
MODIFICATIONS	Stile and rail widths and outside profiles can be altered

SIZE PARAMETERS

DOORS DRAWER FRONTS	5.3" x 5.3" minimum 48" x 96" maximum, warranted to 31" x 60"
REDUCED RAIL DRAWER FRONTS	5.3" x 3" minimum
SLAB DRAWER FRONTS	3" x 3" minimum
OVERLAYS	2.5" x 6" minimum
FRAMES	6.8" x 6.8" minimum 31" x 60" maximum
MULLIONS	9.8" x 9.8" minimum 31" x 60" maximum
MULLION LITES	9.8" to 24" heights = 4 lites 24" to 31" heights = 6 lites 31" to 41" heights = 8 lites 41" to 60" heights = 10 lites
INSERT SIZING	For Standard route subtract 3.875" from width and height to determine insert size with 1/16" clearance on all sides For T-slot route subtract 3.425" from width and height to determine insert size with 1/16" clearance on all sides

SHAKER WIDE



GAUNTLET SUPERMATTE

Door | Drawer Front

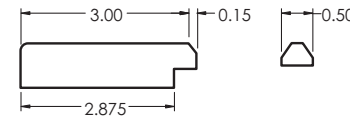
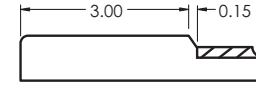

Frame | Mullion

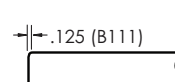

Slab Drawer Front

NEXUS
Robotically sanded, economical alternative to our insert panel shakers

PROFILE SPECIFICATIONS

DOOR STYLE	Square
CONSTRUCTION	Flat drop-in panel Membrane pressed face and sides
FACE MATERIAL	All 3DL color selections High gloss not warranted for warp
CORE	3/4" engineered core 3/4" ULEF core with White TFL back available
BACK MATERIAL	Standard back is White TFL Off-White, Grey, Black or Neutral Maple TFL available at no additional charge Matching back TFL available with select 3DLs for an additional charge
GRAIN DIRECTION	Vertical grain is standard on doors, frames and mullions Horizontal is available, up to 48" in height Horizontal grain is standard on drawer fronts

ADDITIONAL OPTIONS

ROUTE FOR INSERT	Standard frame and mullion route for insert shown T-slot route available Clear, Frosted, or Mirrored glass, and Frosted Acrylic inserts available
MULTI-PANELS	Vertical or horizontal configurations
FINGERPULLS	Standard or custom placement available Not available with high gloss materials
HINGE BORING	See page 3 for standard patterns and placement Custom drilling available
MODIFICATIONS	Stile and rail widths and outside profiles can be altered

SIZE PARAMETERS

DOORS DRAWER FRONTS	7.3" x 7.3" minimum 48" x 96" maximum, warranted to 31" x 60"
REDUCED RAIL DRAWER FRONTS	7.3" x 3" minimum
SLAB DRAWER FRONTS	3" x 3" minimum
OVERLAYS	2.5" x 6" minimum
FRAMES	8.8" x 8.8" minimum 31" x 60" maximum
MULLIONS	11.8" x 11.8" minimum 31" x 60" maximum
MULLION LITES	11.8" to 24" heights = 4 lites 24" to 31" heights = 6 lites 31" to 41" heights = 8 lites 41" to 60" heights = 10 lites
INSERT SIZING	For Standard route subtract 5.875" from width and height to determine insert size with 1/16" clearance on all sides For T-slot route subtract 5.425" from width and height to determine insert size with 1/16" clearance on all sides



SHAKER BEVEL

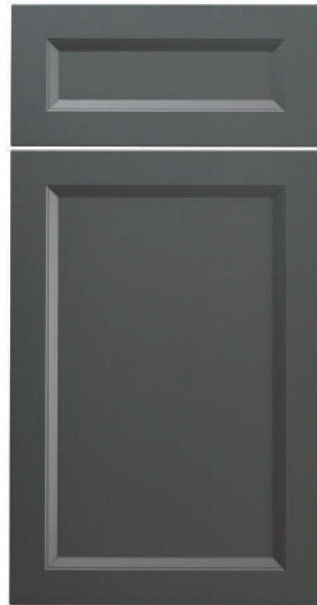

FLINT SUPERMATTE

Door | Drawer Front

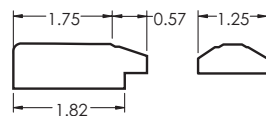
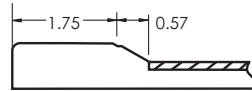

Frame | Mullion

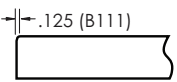

Slab Drawer Front

NEXUS
 Robotically sanded, economical alternative to our insert panel shakers

PROFILE SPECIFICATIONS

DOOR STYLE	Square
CONSTRUCTION	Flat drop-in panel Membrane pressed face and sides
FACE MATERIAL	All 3DL color selections High gloss not warranted for warp
CORE	3/4" engineered core 3/4" ULEF core with White TFL back available
BACK MATERIAL	Standard back is White TFL Off-White, Grey, Black or Neutral Maple TFL available at no additional charge Matching back TFL available with select 3DLs for an additional charge
GRAIN DIRECTION	Vertical grain is standard on doors, frames and mullions Horizontal is available, up to 48" in height Horizontal grain is standard on drawer fronts

ADDITIONAL OPTIONS

GLAZE	Charcoal, Walnut or White on select materials
ROUTE FOR INSERT	Standard frame and mullion route for insert shown T-slot route available Clear, Frosted, or Mirrored glass, and Frosted Acrylic inserts available
MULTI-PANELS	Vertical or horizontal configurations
FINGERPULLS	Standard or custom placement available Not available with high gloss materials
HINGE BORING	See page 3 for standard patterns and placement Custom drilling available
MODIFICATIONS	Stile and rail widths and outside profiles can be altered

SIZE PARAMETERS

DOORS DRAWER FRONTS	5.65" x 5.65" minimum 48" x 96" maximum, warranted to 31" x 60"
REDUCED RAIL DRAWER FRONTS	5.65" x 3.15" minimum
SLAB DRAWER FRONTS	3" x 3" minimum
OVERLAYS	2.5" x 6" minimum
FRAMES	7.15" x 7.15" minimum 31" x 60" maximum
MULLIONS	10.9" x 10.9" minimum 31" x 60" maximum
MULLION LITES	10.9" to 24" heights = 4 lites 24" to 31" heights = 6 lites 31" to 41" heights = 8 lites 41" to 60" heights = 10 lites
INSERT SIZING	For Standard route subtract 3.771" from width and height to determine insert size with 1/16" clearance on all sides For T-slot route subtract 3.771" from width and height to determine insert size with 1/16" clearance on all sides

SHAKER OGEE



HAZE SUPERMATTE

Door | Drawer Front

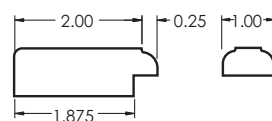
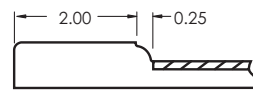

Frame | Mullion

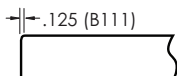

Slab Drawer Front

NEXUS
 Robotically sanded, economical alternative to our insert panel shakers

PROFILE SPECIFICATIONS

DOOR STYLE	Square
CONSTRUCTION	Flat drop-in panel Membrane pressed face and sides
FACE MATERIAL	All 3DL color selections High gloss not warranted for warp
CORE	3/4" engineered core 3/4" ULEF core with White TFL back available
BACK MATERIAL	Standard back is White TFL Off-White, Grey, Black or Neutral Maple TFL available at no additional charge Matching back TFL available with select 3DLs for an additional charge
GRAIN DIRECTION	Vertical grain is standard on doors, frames and mullions Horizontal is available, up to 48" in height Horizontal grain is standard on drawer fronts

ADDITIONAL OPTIONS

GLAZE	Charcoal, Walnut or White on select materials
ROUTE FOR INSERT	Standard frame and mullion route for insert shown T-slot route available Clear, Frosted, or Mirrored glass, and Frosted Acrylic inserts available
MULTI-PANELS	Vertical or horizontal configurations
FINGERPULLS	Standard or custom placement available Not available with high gloss materials
HINGE BORING	See page 3 for standard patterns and placement Custom drilling available
MODIFICATIONS	Stile and rail widths and outside profiles can be altered

SIZE PARAMETERS

DOORS DRAWER FRONTS	5.3" x 5.3" minimum 48" x 96" maximum, warranted to 31" x 60"
REDUCED RAIL DRAWER FRONTS	5.3" x 3" minimum
SLAB DRAWER FRONTS	3" x 3" minimum
OVERLAYS	2.5" x 6" minimum
FRAMES	7" x 7" minimum 31" x 60" maximum
MULLIONS	10.5" x 10.5" minimum 31" x 60" maximum
MULLION LITES	10.5" to 24" heights = 4 lites 24" to 31" heights = 6 lites 31" to 41" heights = 8 lites 41" to 60" heights = 10 lites
INSERT SIZING	For Standard route subtract 3.875" from width and height to determine insert size with 1/16" clearance on all sides For T-slot route subtract 3.625" from width and height to determine insert size with 1/16" clearance on all sides



LANCASTER

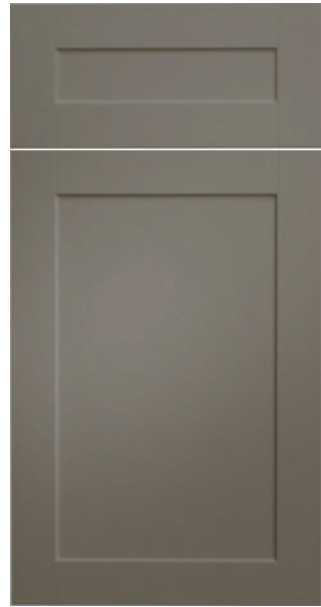

GAUNTLET SUPERMATTE

Door | Drawer Front

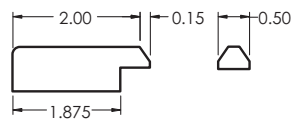
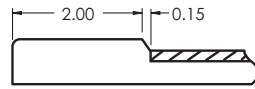

Frame | Mullion

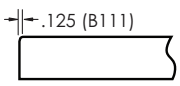

Slab Drawer Front



Slab Drawer Front with Vertical Lines

NEXUS
 Robotically sanded, economical alternative to our insert panel shakers

PROFILE SPECIFICATIONS	
DOOR STYLE	Square
CONSTRUCTION	Stile and rail detail for 5-piece appearance Flat drop-in panel Membrane pressed face and sides
FACE MATERIAL	All 3DL color selections High gloss not warranted for warp
CORE	3/4" engineered core 3/4" ULEF core with White TFL back available
BACK MATERIAL	Standard back is White TFL Off-White, Grey, Black or Neutral Maple TFL available at no additional charge Matching back TFL available with select 3DLs for an additional charge
GRAIN DIRECTION	Vertical grain is standard on doors, frames and mullions Horizontal is available, up to 48" in height Horizontal grain is standard on drawer fronts

ADDITIONAL OPTIONS	
ROUTE FOR INSERT	Standard frame and mullion route for insert shown T-slot route available Clear, Frosted, or Mirrored glass, and Frosted Acrylic inserts available
MULTI-PANELS	Vertical or horizontal configurations
FINGERPULLS	Standard or custom placement available Not available with high gloss materials
HINGE BORING	See page 3 for standard patterns and placement Custom drilling available
MODIFICATIONS	Stile and rail widths and outside profiles can be altered

SIZE PARAMETERS	
DOORS DRAWER FRONTS	5.3" x 5.3" minimum 48" x 96" maximum, warranted to 31" x 60"
REDUCED RAIL DRAWER FRONTS	5.3" x 3" minimum
SLAB DRAWER FRONTS	3" x 3" minimum
OVERLAYS	2.5" x 6" minimum
FRAMES	6.8" x 6.8" minimum 31" x 60" maximum
MULLIONS	10.875" x 10.875" minimum 31" x 60" maximum
MULLION LITES	10.875" to 24" heights = 4 lites 24" to 31" heights = 6 lites 31" to 41" heights = 8 lites 41" to 60" heights = 10 lites
INSERT SIZING	For Standard route subtract 3.875" from width and height to determine insert size with 1/16" clearance on all sides For T-slot route subtract 3.425" from width and height to determine insert size with 1/16" clearance on all sides

SHAKER ELITE



BISQUE

Door | Drawer Front

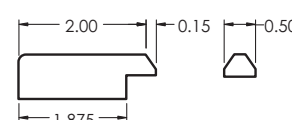
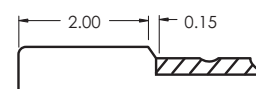

Frame | Mullion

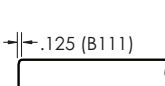

Slab Drawer Front

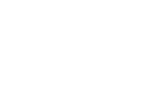

Slab Drawer Front

PROFILE SPECIFICATIONS	
DOOR STYLE	Square
CONSTRUCTION	Routed drop-in panel Membrane pressed face and sides
FACE MATERIAL	All 3DL color selections, except high gloss
CORE	3/4" engineered core 3/4" ULEF core with White TFL back available
BACK MATERIAL	Standard back is White TFL Off-White, Grey, Black or Neutral Maple TFL available at no additional charge Matching back TFL available with select 3DLs for an additional charge
GRAIN DIRECTION	Vertical grain is standard on doors, frames and mullions Horizontal is available, up to 48" in height Horizontal grain is standard on drawer fronts

ADDITIONAL OPTIONS	
ROUTE FOR INSERT	Standard frame and mullion route for insert shown T-slot route available Clear, Frosted, or Mirrored glass, and Frosted Acrylic inserts available
MULTI-PANELS	Vertical or horizontal configurations
FINGERPULLS	Standard or custom placement available
HINGE BORING	See page 3 for standard patterns and placement Custom drilling available
MODIFICATIONS	Stile and rail widths and outside profiles can be altered

SIZE PARAMETERS	
DOORS DRAWER FRONTS	5.3" x 5.3" minimum 48" x 96" maximum, warranted to 31" x 60"
REDUCED RAIL DRAWER FRONTS	5.3" x 3" minimum
SLAB DRAWER FRONTS	3" x 3" minimum
OVERLAYS	2.5" x 6" minimum
FRAMES	6.8" x 6.8" minimum 31" x 60" maximum
MULLIONS	9.8" x 9.8" minimum 31" x 60" maximum
MULLION LITES	9.8" to 24" heights = 4 lites 24" to 31" heights = 6 lites 31" to 41" heights = 8 lites 41" to 60" heights = 10 lites
INSERT SIZING	For Standard route subtract 3.875" from width and height to determine insert size with 1/16" clearance on all sides For T-slot route subtract 3.425" from width and height to determine insert size with 1/16" clearance on all sides



SHAKER INSET



SURF SUPERMATTE

Door | Drawer Front

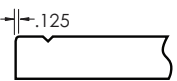
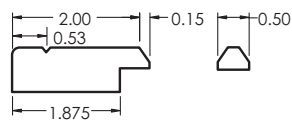
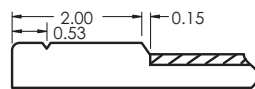

Slab Drawer Front with Edge Detail

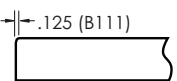

Slab Drawer Front



Robotically sanded, economical alternative to our insert panel shakers

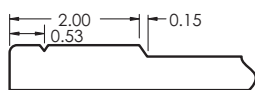

PROFILE SPECIFICATIONS

DOOR STYLE	Square
CONSTRUCTION	Flat drop-in panel with routed edge detail Membrane pressed face and sides
FACE MATERIAL	All 3DL color selections High gloss not warranted for warp
CORE	3/4" engineered core 3/4" ULEF core with White TFL back available
BACK MATERIAL	Standard back is White TFL Off-White, Grey, Black or Neutral Maple TFL available at no additional charge Matching back TFL available with select 3DLs for an additional charge
GRAIN DIRECTION	Vertical grain is standard on doors, frames and mullions Horizontal is available, up to 48" in height Horizontal grain is standard on drawer fronts

ADDITIONAL OPTIONS

ROUTE FOR INSERT	Standard frame and mullion route for insert shown T-slot route available Clear, Frosted, or Mirrored glass, and Frosted Acrylic inserts available
MULTI-PANELS	Vertical or horizontal configurations
FINGERPULLS	Standard or custom placement available Not available with high gloss materials
HINGE BORING	See page 3 for standard patterns and placement Custom drilling available
MODIFICATIONS	Stile and rail widths can be altered

SIZE PARAMETERS

DOORS DRAWER FRONTS	5.3" x 5.3" minimum 48" x 96" maximum, warranted to 31" x 60"
REDUCED RAIL DRAWER FRONTS	5.3" x 3" minimum
SLAB DRAWER FRONTS	3" x 3" minimum
OVERLAYS	2.5" x 6" minimum
FRAMES	6.8" x 6.8" minimum 31" x 60" maximum
MULLIONS	9.8" x 9.8" minimum 31" x 60" maximum
MULLION LITES	9.8" to 24" heights = 4 lites 24" to 31" heights = 6 lites 31" to 41" heights = 8 lites 41" to 60" heights = 10 lites
INSERT SIZING	For Standard route subtract 3.875" from width and height to determine insert size with 1/16" clearance on all sides For T-slot route subtract 3.425" from width and height to determine insert size with 1/16" clearance on all sides

SHAKER LOUVRE

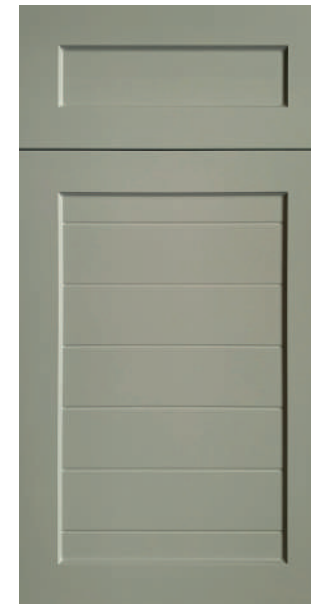

ALOE SUPERMATTE

Door | Drawer Front

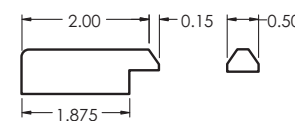
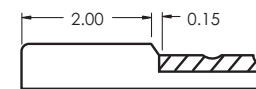

Frame | Mullion

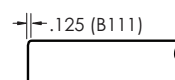

Slab Drawer Front

PROFILE SPECIFICATIONS

DOOR STYLE	Square
CONSTRUCTION	Routed drop-in panel with 3" horizontal spacing Membrane pressed face and sides
FACE MATERIAL	All 3DL color selections High gloss not warranted for warp
CORE	3/4" engineered core 3/4" ULEF core with White TFL back available
BACK MATERIAL	Standard back is White TFL Off-White, Grey, Black or Neutral Maple TFL available at no additional charge Matching back TFL available with select 3DLs for an additional charge
GRAIN DIRECTION	Vertical grain is standard on doors, frames and mullions Horizontal is available, up to 48" in height Horizontal grain is standard on drawer fronts

ADDITIONAL OPTIONS

ROUTE FOR INSERT	Standard frame and mullion route for insert shown T-slot route available Clear, Frosted, or Mirrored glass, and Frosted Acrylic inserts available
MULTI-PANELS	Vertical or horizontal configurations
FINGERPULLS	Standard or custom placement available Not available with high gloss materials
HINGE BORING	See page 3 for standard patterns and placement Custom drilling available
MODIFICATIONS	Stile and rail widths and outside profiles can be altered

SIZE PARAMETERS

DOORS DRAWER FRONTS	5.3" x 5.2" minimum 48" x 96" maximum, warranted to 31" x 60" Drawer Fronts under 8.2" high will not have a routed panel
REDUCED RAIL DRAWER FRONTS	5.3" x 3" minimum Drawer Fronts under 8.2" high will not have a routed panel
SLAB DRAWER FRONTS	3" x 3" minimum
OVERLAYS	2.5" x 6" minimum
FRAMES	6.8" x 6.8" minimum 31" x 60" maximum
MULLIONS	9.8" x 9.8" minimum 31" x 60" maximum
MULLION LITES	9.8" to 24" heights = 4 lites 24" to 31" heights = 6 lites 31" to 41" heights = 8 lites 41" to 60" heights = 10 lites
INSERT SIZING	For Standard route subtract 3.875" from width and height to determine insert size with 1/16" clearance on all sides For T-slot route subtract 3.425" from width and height to determine insert size with 1/16" clearance on all sides



AMESBURY III



ADOBE rPET

Door | Drawer Front

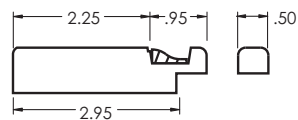
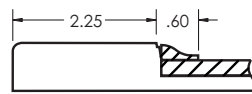

Frame | Mullion



Shown With Glaze



Robotically sanded, economical alternative to our insert panel shakers

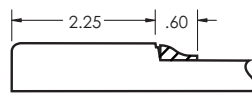

PROFILE SPECIFICATIONS

DOOR STYLE	Square
CONSTRUCTION	Applied moulding and flat drop-in panel Membrane pressed face and sides
FACE MATERIAL	Available in all 3DL color selections, except high gloss
CORE	3/4" engineered core 3/4" ULEF core with White TFL back available
BACK MATERIAL	Standard back is White TFL Off-White, Grey, Black or Neutral Maple TFL available at no additional charge Matching back TFL available with select 3DLs for an additional charge
GRAIN DIRECTION	Vertical grain is standard on doors, frames and mullions Horizontal is available, up to 48" in height Horizontal grain is standard on drawer fronts

ADDITIONAL OPTIONS

GLAZE	Charcoal, Walnut or White on select materials
ROUTE FOR GLASS	Standard frame and mullion route for insert shown T-slot route available Clear, Frosted, or Mirrored glass, and Frosted Acrylic inserts available
MULTI-PANELS	Vertical or horizontal configurations
FINGERPULLS	Standard or custom placement available
HINGE BORING	See page 3 for standard patterns and placement Custom drilling available
MODIFICATIONS	Stile and rail widths and outside profiles can be altered

SIZE PARAMETERS

DOORS DRAWER FRONTS	6.75" x 6.75" minimum 48" x 96" maximum, warranted to 31" x 60"
REDUCED RAIL DRAWER FRONTS	6.75" x 3.8" minimum
SLAB DRAWER FRONTS	3" x 3" minimum
OVERLAYS	2.5" x 6" minimum
FRAMES	10.5" x 10.5" minimum 31" x 60" maximum
MULLIONS	13" x 13" minimum 31" x 60" maximum
MULLION LITES	13" to 24" heights = 4 lites 24" to 31" heights = 6 lites 31" to 41" heights = 8 lites 41" to 60" heights = 10 lites
INSERT SIZING	For Standard route subtract 6.025" from width and height to determine insert size with 1/16" clearance on all sides For T-slot route subtract 5.525" from width and height to determine insert size with 1/16" clearance on all sides

ASPEN



SAGE SUPERMATTE

Door | Drawer Front

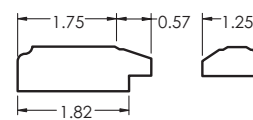
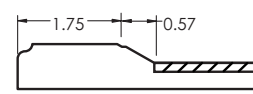

Frame | Mullion



Shown With Glaze



Robotically sanded, economical alternative to our insert panel shakers

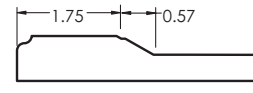

PROFILE SPECIFICATIONS

DOOR STYLE	Square
CONSTRUCTION	Flat drop-in panel Membrane pressed face and sides
FACE MATERIAL	All 3DL color selections High gloss not warranted for warp
CORE	3/4" engineered core 3/4" ULEF core with White TFL back available
BACK MATERIAL	Standard back is White TFL Off-White, Grey, Black or Neutral Maple TFL available at no additional charge Matching back TFL available with select 3DLs for an additional charge
GRAIN DIRECTION	Vertical grain is standard on doors, frames and mullions Horizontal is available, up to 48" in height Horizontal grain is standard on drawer fronts

ADDITIONAL OPTIONS

GLAZE	Charcoal, Walnut or White on select materials
ROUTE FOR INSERT	Standard frame and mullion route for glass shown T-slot route available Clear, Frosted, or Mirrored glass, and Frosted Acrylic inserts available
MULTI-PANELS	Vertical or horizontal configurations
FINGERPULLS	Standard or custom placement available Not available with high gloss materials
HINGE BORING	See page 3 for standard patterns and placement Custom drilling available
MODIFICATIONS	Stile and rail widths and outside profiles can be altered

SIZE PARAMETERS

DOORS DRAWER FRONTS	5.65" x 5.65" minimum 48" x 96" maximum, warranted to 31" x 60"
REDUCED RAIL DRAWER FRONTS	5.65" x 3" minimum
SLAB DRAWER FRONTS	3" x 3" minimum
OVERLAYS	2.5" x 6" minimum
FRAMES	7.64" x 7.64" minimum 31" x 60" maximum
MULLIONS	10.875" x 10.875" minimum 31" x 60" maximum
MULLION LITES	10.875" to 24" heights = 4 lites 24" to 31" heights = 6 lites 31" to 41" heights = 8 lites 41" to 60" heights = 10 lites
INSERT SIZING	For Standard route subtract 3.771" from width and height to determine insert size with 1/16" clearance on all sides For T-slot route subtract 3.771" from width and height to determine insert size with 1/16" clearance on all sides



CLASSIC



STRATUS SUPERMATTE

Door | Drawer Front

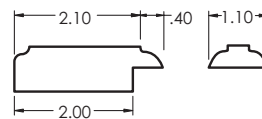
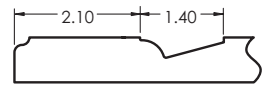

Frame | Mullion



Charcoal Glaze



Walnut Glaze



White Glaze

PROFILE SPECIFICATIONS

DOOR STYLE	Square, Arch or Cathedral
CONSTRUCTION	Raised center panel Membrane pressed face and sides
FACE MATERIAL	All 3DL color selections
CORE	3/4" engineered core 3/4" ULEF core with White TFL back available
BACK MATERIAL	Standard back is White TFL Off-White, Grey, Black or Neutral Maple TFL available at no additional charge Matching back TFL available with select 3DLs for an additional charge
GRAIN DIRECTION	Vertical grain is standard on doors, frames and mullions Horizontal is available, up to 48" in height Horizontal grain is standard on drawer fronts

ADDITIONAL OPTIONS

GLAZE	Charcoal, Walnut or White on select materials
ROUTE FOR INSERT	Standard frame and mullion route for insert shown T-slot route available Clear, Frosted, or Mirrored glass, and Frosted Acrylic inserts available
MULTI-PANELS	Vertical or horizontal configurations
FINGERPULLS	Standard or custom placement available Not available with high gloss materials
HINGE BORING	See page 3 for standard patterns and placement Custom drilling available
MODIFICATIONS	Stile and rail widths and outside profiles can be altered

SIZE PARAMETERS

DOORS DRAWER FRONTS	8" x 8" square minimum 11.125" x 11.125" arch and cathedral minimum 48" x 96" maximum, warranted to 31" x 60"
REDUCED RAIL DRAWER FRONTS	8" x 5.3" square minimum
SLAB DRAWER FRONTS	3" x 3" minimum
OVERLAYS	2.5" x 6" minimum
FRAMES	9.125" x 9.125" square minimum 9.625" x 9.625" arch minimum 10.125" x 10.125" cathedral minimum 31" x 60" maximum
MULLIONS	12.25" x 12.25" square minimum 13.25" x 13.25" arch and cathedral minimum 31" x 60" maximum
MULLION LITES	12.25" to 24" heights = 4 lites 24" to 31" heights = 6 lites 31" to 41" heights = 8 lites 41" to 60" heights = 10 lites
INSERT SIZING	For Standard route subtract 4.125" from width and height to determine insert size with 1/16" clearance on all sides For T-slot route subtract 4.125" from width and height to determine insert size with 1/16" clearance on all sides

CLASSIC II



BAJA rPET

Door | Drawer Front

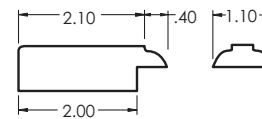
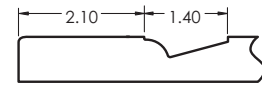

Frame | Mullion



Shown With Glaze

PROFILE SPECIFICATIONS

DOOR STYLE	Square, Arch or Cathedral
CONSTRUCTION	Raised center panel Membrane pressed face and sides
FACE MATERIAL	All 3DL color selections
CORE	3/4" engineered core 3/4" ULEF core with White TFL back available
BACK MATERIAL	Standard back is White TFL Off-White, Grey, Black or Neutral Maple TFL available at no additional charge Matching back TFL available with select 3DLs for an additional charge
GRAIN DIRECTION	Vertical grain is standard on doors, frames and mullions Horizontal is available, up to 48" in height Horizontal grain is standard on drawer fronts

ADDITIONAL OPTIONS

GLAZE	Charcoal, Walnut or White on select materials
ROUTE FOR INSERT	Standard frame and mullion route for insert shown T-slot route available Clear, Frosted, or Mirrored glass, and Frosted Acrylic inserts available
MULTI-PANELS	Vertical or horizontal configurations
FINGERPULLS	Standard or custom placement available Not available with high gloss materials
HINGE BORING	See page 3 for standard patterns and placement Custom drilling available
MODIFICATIONS	Stile and rail widths and outside profiles can be altered

SIZE PARAMETERS

DOORS DRAWER FRONTS	8" x 8" square minimum 11.125" x 11.125" arch and cathedral minimum 48" x 96" maximum, warranted to 31" x 60"
REDUCED RAIL DRAWER FRONTS	8" x 5.3" square minimum
SLAB DRAWER FRONTS	3" x 3" minimum
OVERLAYS	2.5" x 6" minimum
FRAMES	9.125" x 9.125" square minimum 9.625" x 9.625" arch minimum 10.125" x 10.125" cathedral minimum 31" x 60" maximum
MULLIONS	12.25" x 12.25" square minimum 13.25" x 13.25" arch and cathedral minimum 31" x 60" maximum
MULLION LITES	12.25" to 24" heights = 4 lites 24" to 31" heights = 6 lites 31" to 41" heights = 8 lites 41" to 60" heights = 10 lites
INSERT SIZING	For Standard route subtract 4.125" from width and height to determine insert size with 1/16" clearance on all sides For T-slot route subtract 4.125" from width and height to determine insert size with 1/16" clearance on all sides



Legacy Profiles represent a collection of classic profiles, echoing the craftsmanship of the past. These profiles are still available to order; however, we encourage you to design your new projects with the more current profiles presented in the rest of this Product Guide.

LANCASTER WIDE



MIDNIGHT SUPERMATTE

Door | Drawer Front

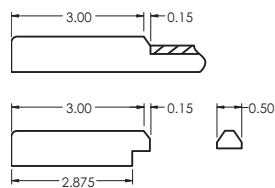

LANCASTER ELITE

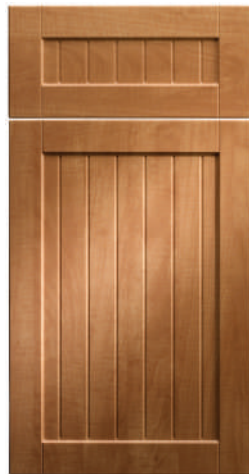

CANDLELIGHT

Door | Drawer Front

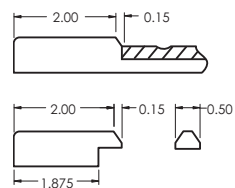

MANCHESTER II



WHITE SATIN

Door | Drawer Front

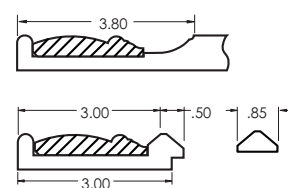

MANCHESTER III



BISQUE

Door | Drawer Front

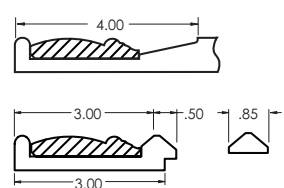

WELLINGTON



NAVY SUPERMATTE

Door | Drawer Front

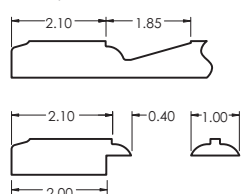

BRADFORD



BISQUE

Door | Drawer Front

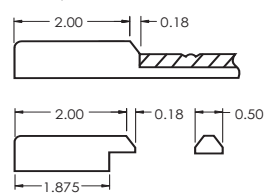

AMESBURY II



SNOW WHITE

Door | Drawer Front

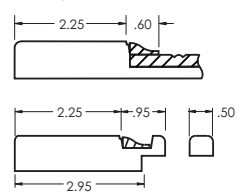

BRECKENRIDGE



WHITE SATIN

Door | Drawer Front

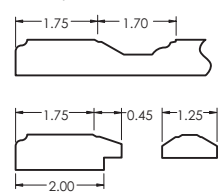

ELEGANTE II
WHITE GLOSS + FRAME WITH FROSTED GLASS

Personalize your components with the Select Series. If you don't see your desired profile design in our standard offering, create something more custom by choosing from our library of inside and outside profile options.

1 DOOR STYLE OPTIONS

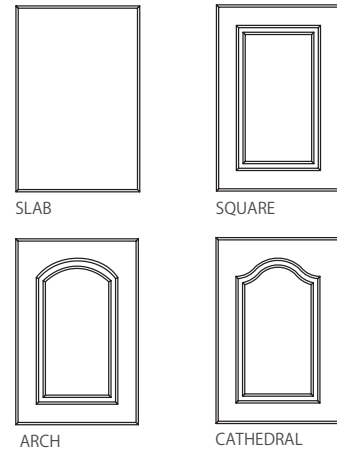

2 OUTSIDE PROFILE OPTIONS

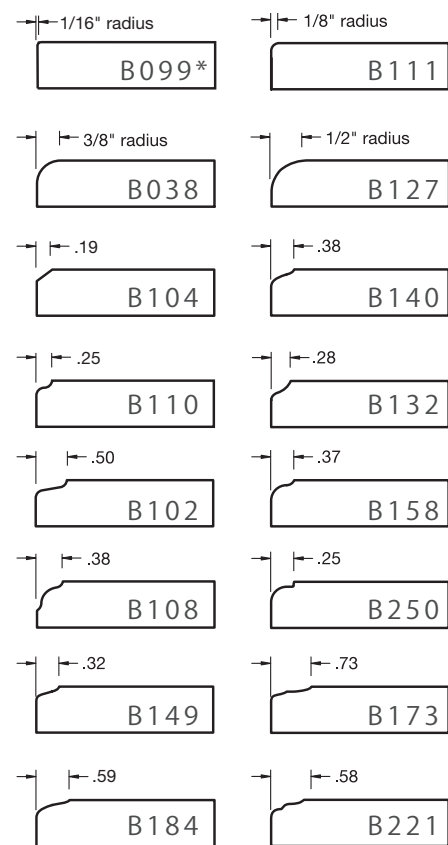

*B099 not recommended for all materials. Thinning or effacing may occur on the corners. Material thickness, color, in-use application, and lighting are considerations.

3 INSIDE PROFILE OPTIONS

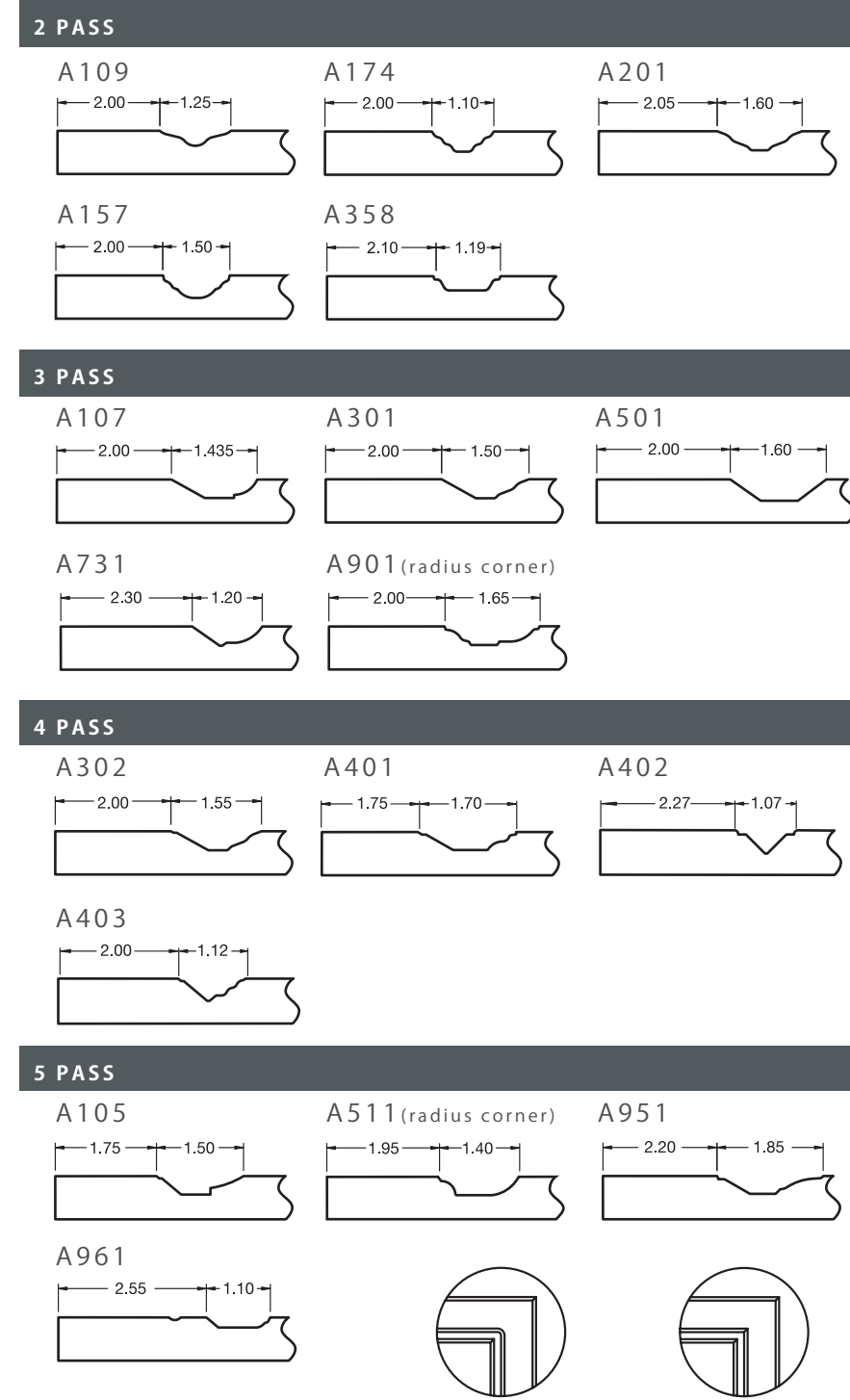

All 2 Pass profiles and A511 & A901 will have radius corners. All other 3, 4 and 5 Pass profiles will have square corners.

BARE SHAKER

PAINTABLE MDF SHAKER AND SLAB COMPONENTS

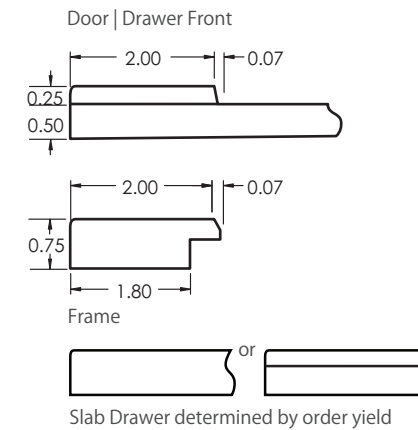

PROFILE SPECIFICATIONS

DOOR STYLE	Square
CONSTRUCTION	1/16" radius outside edges 1/4" depth on center panel 85 degree inside bevel
CORE MATERIAL	Shaker Door/Dwr: Superior grade 1/4" + 1/2" MDF Slab Door: Superior grade 3/4" MDF Slab Dwr: Superior grade 1/4" + 1/2" MDF or 3/4" MDF
BARE SHAKER COMPONENTS	Door, Dwr, Slab Dwr, Overlay, Frame, Multi-Panel

ADDITIONAL OPTIONS

ROUTE FOR INSERT	3/4" MDF Standard frame route for insert shown T-slot route available Clear, Frosted, or Mirrored glass, and Frosted Acrylic inserts available
MULTI-PANELS	Vertical or horizontal configurations
FINGERPULLS	N/A
HINGE BORING	See page 3 for standard patterns and placement Custom drilling available
MODIFICATIONS	N/A

SIZE PARAMETERS

DOORS DRAWER FRONTS	5.134" x 5.134" minimum 47" x 95" maximum, warranted to 31" x 60"
REDUCED RAIL DRAWER FRONTS	N/A
SLAB DRAWER FRONTS	3" x 3" minimum
OVERLAYS	2.5" x 6" minimum
FRAMES	6.634" x 6.634" minimum 31" x 60" maximum
INSERT SIZING	For Standard route subtract 3.709" from width and height to determine insert size with 1/16" clearance on all sides For T-slot route subtract 3.459" from width and height to determine insert size with 1/16" clearance on all sides

UNFINISHED COMPONENTS

PAINTING PREPARATION	All components are sold unfinished. We recommend sanding and priming before painting to obtain a consistent finish.
	Unfinished components are warranted for a period of ONE (1) YEAR.
	Unfinished components must be stored in a climate-controlled environment to minimize expansion and contraction and finished within 30 days. Problems related to poor or improper sealing, painting, or finishing applied by others are excluded from this warranty.

3DL SURFACES



3/4" SLOPE, WATERFALL, LEDGE PROFILES



CLIFF PROFILE | CARRARA

Durable and ergonomic, 3DL Surfaces are a superior alternative to traditional HPL and TFL (melamine) products. 3DL is a non-porous material membrane pressed over the top and edges of each component eliminating the vulnerabilities to bacteria, moisture, and damage commonly seen with edgebanded products.

Our materials endure rigorous, comprehensive, state-of-the-art testing by an independent source. Each test reflected in the data below was conducted using a standard white 3D laminate, white powder coated, white HPL, and white melamine component on an engineered core.

HOFFMAN SCRATCH

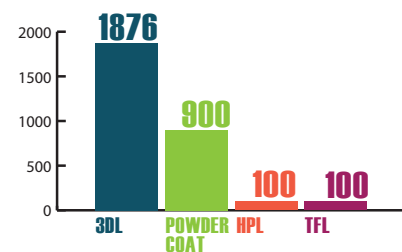

Grams of weight needed before removal of material occurs.

IMPACT RESISTANCE

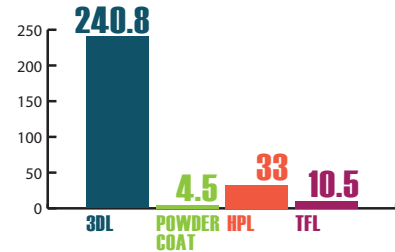

Drop height multiplied by a 4.5 lb impact weight showing inch pounds needed before material integrity is compromised.

TABER ABRASION

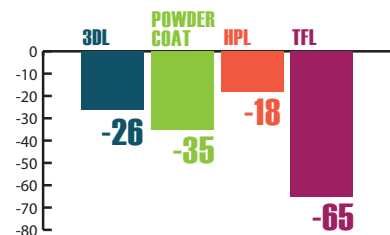

Milligrams of material weight loss after 1000 cycles. Note: 3DL wear was only on clear top layers, leaving color intact.

PROFILE SPECIFICATIONS	
CONSTRUCTION	Membrane pressed face and sides
FACE MATERIAL	All PerformEx 3DL color selections
CORE	3/4" or 1" engineered core
BACK MATERIAL	3/4" White, Off-White, Grey, Black, Neutral Maple, Matching back TFL available with select 3DLs 1" available in Black or White TFL
GRAIN DIRECTION	As shown on drawings
ADDITIONAL OPTIONS	
MODIFICATIONS	Custom surfaces available through our Contract Division
SIZE PARAMETERS	
MINS AND MAXES	12" x 12" minimum 47" maximum width 96" maximum length Corner radii is 3/16"

PROFILE OPTIONS

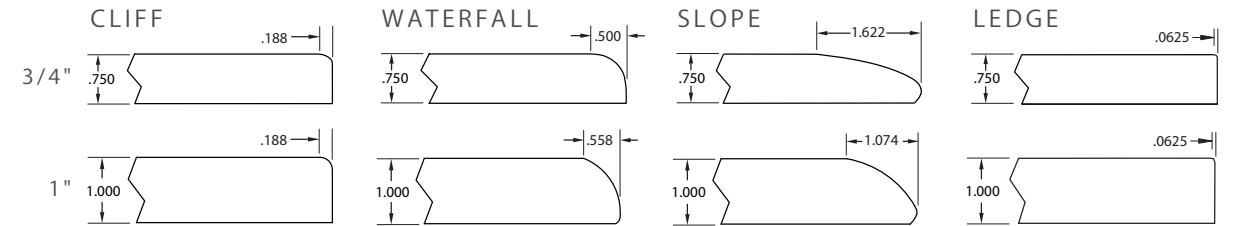

STANDARD SHAPES

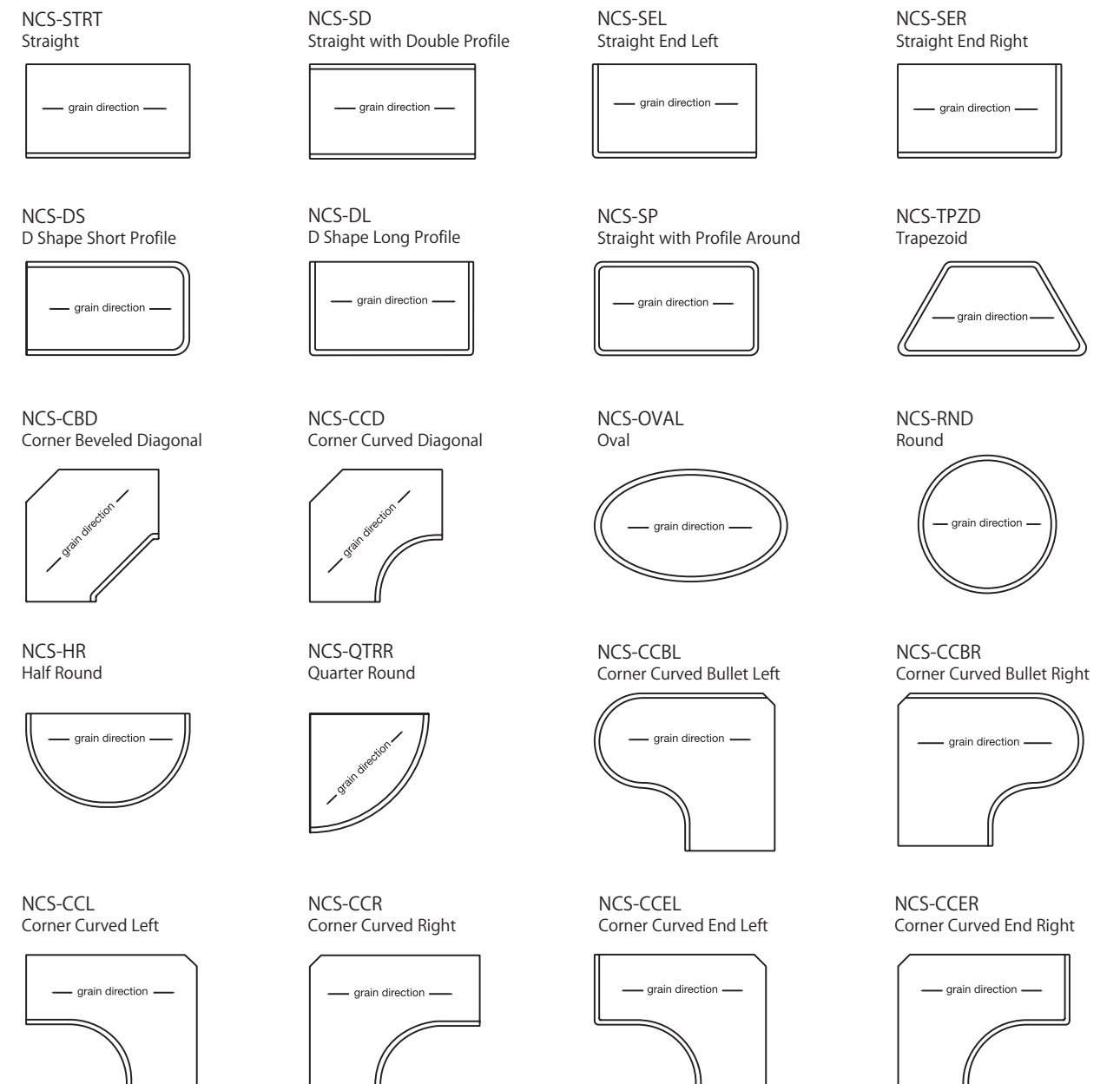

5

WOOD VENEER internally edgebanded

NATURAL WOOD VENEER

Each natural veneer has unique characteristics and variations specific to the species. These variations in grain and color are inherent in the veneer, and components may have a natural crossbar figure or slight bending ray fleck. These are considered natural characteristics of wood and will not be replaced without a charge. We use veneer grades based on standard HPVA specifications.

RECONSTITUTED WOOD VENEER

Reconstituted wood veneer is an engineered product that gives you superior color and grain consistency while also offering an environmentally responsible alternative to endangered or extremely rare wood species.

BOARD SPECIFICATIONS

Components are made with a high quality, CARB Phase 2 ATCM 93120 compliant, 3/4" engineered core. An engineered core provides a stable, consistent substrate, virtually eliminating warping. Ultra Low Emitting Formaldehyde (ULEF) options available by special request. We reserve the right to use a particleboard core of equal density in certain situations.

EDGE-BANDING SPECIFICATIONS

Wood Veneer components are internally edgebanded with 2 or 3 mm, multi-layered wood veneer unless otherwise noted. Application is shown below.

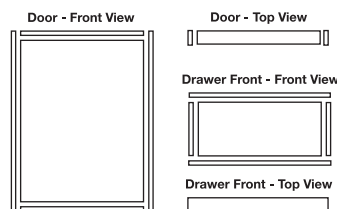

ORDERING WOOD VENEER

We strive to match veneer appearance for wood veneer order additions and replacements. However, late additions to orders and replacement doors will likely be produced from different veneer stock. For best results in matching, be sure orders are complete when placed. With larger projects, placing orders for each room is recommended.

UNFINISHED COMPONENT CARE

All unfinished doors are sanded in a progression up to a 220-grit sandpaper. We recommend also using a 220-grit sandpaper prior to finishing. Use care to avoid sanding through the veneer, which may expose the core material. Real wood veneer is a unique product of nature so each piece or section may accept stain differently. We recommend using a sanding sealer and/or wood toner to maintain a consistent finish. Unfinished components must be stored in a climate-controlled environment to minimize expansion and contraction.

VENEER CUTS



Plain Sliced veneer is cut straight through the log from one side to the other producing the common cathedral grain pattern. This slicing method will create some areas with a straight grain appearance on the sides.

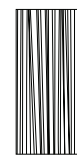

Quartered or Rift Cut veneer is used to achieve veneer with a straight grain. In quarter sawn, the quarter of a log is placed so that the growth rings are perpendicular to the cutting blade creating a straight grain pattern. Rift Slicing achieves a similar grain pattern but avoids the appearance of "flake" that occurs in some species when quarter sawn.

SLIP MATCHING

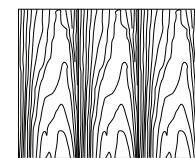

Slip Match is standard. The veneer pieces are placed in sequence as shown with the grain pattern repeating itself.

PAINTABLE DOORS

Paint Grade Maple is available.

GRAIN MATCHING



Custom grain matching capabilities are available, not to exceed 96" in length or height. Not all profiles or species are conducive to grain matching. Elevation drawings are required. Each project is unique and will be quoted on a case by case basis.

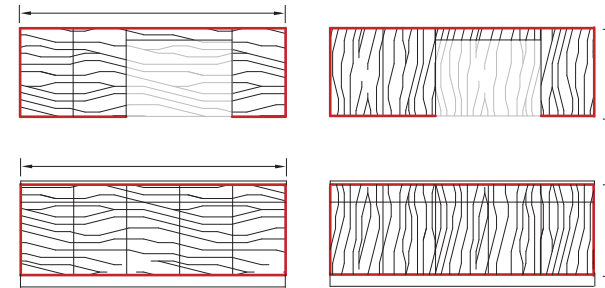

OVERLAYS

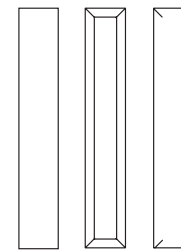

Minimum width is 2 7/8". Maximum length is 96". Overlays will be profiled and edgebanded on all four sides to match door and drawer fronts. See "Cut-to-Size Panels" if raw edges are desired.

SPLIT OVERLAYS

Overlays can be split down the middle to create a variety of decorative details. Minimum width is 2 7/8". We do not cut overlays in our manufacturing facilities; this is simply an idea of how our product can be utilized.

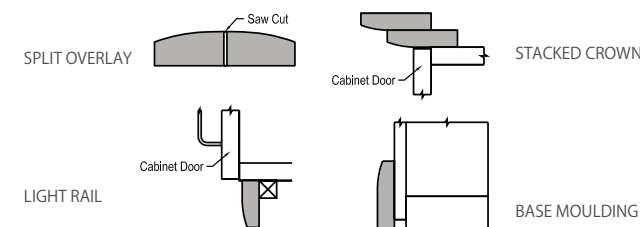

MOULDINGS

Straight Crown, Cove Crown and Scribe mouldings are available in 8' lengths.

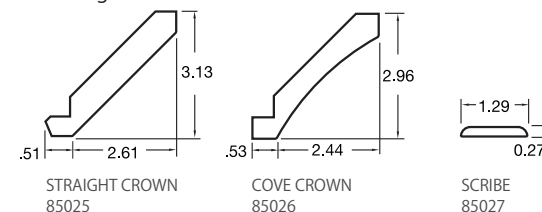

FRAMES

Frames are produced using engineered core material, wood veneer and solid wood inlay sticking. After the frame has been routed, the visible portion is SOLID WOOD rather than the engineered core. We carry Red Oak, Maple, Cherry and Black Walnut solid lumber. The chart below shows how the veneer and solid wood will be paired. Appliance frames with raw or finished inside edges are available. Multi-opening frames are available.

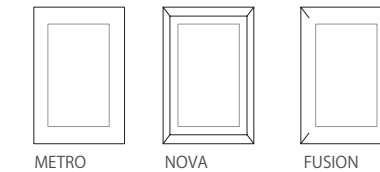

SOLID WOOD STICKING	FRAME VENEER SPECIES
RED OAK	Red Oak, White Oak, Bamboo
MAPLE	Maple, Nordic SG
CHERRY	Cherry, Red Gum
BLACK WALNUT	Walnut, Terra SG, Lincoln Oak, Smoked Grey

GLASS RETAINER CLIPS AND STRIPS

Retainer clips and clear retainer strips are available for purchase. See profile for guidelines on determining sizes.

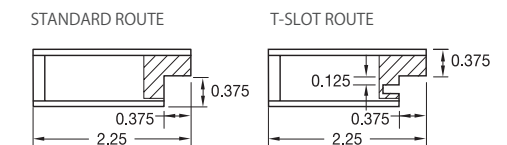

FLOATING SHELVES

Miter folded floating shelves are available in all wood veneer species. Standard height is 2"; standard depth is 10". Available in 1/16" width increments from 22.5" to 72". Standard grain direction will be horizontal on top, bottom and front edge. Ends will have vertical grain. Option of horizontal grain top, bottom and all edges. Metal brackets are included with your order. Max load weight for included bracket is 10 lbs per lineal foot.

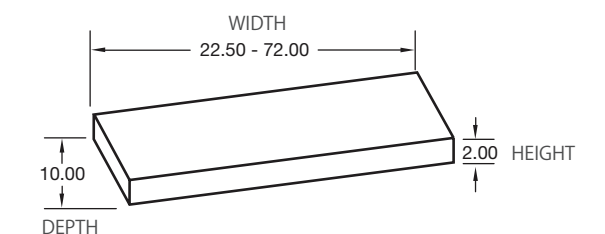



CUT-TO-SIZE PANELS

Available in 1/4", 1/2" or 3/4" thicknesses. Face will be A grade veneer with raw edges and #2 backs. Maximum size is 30" x 96".

SHEET STOCK

Available in 4' x 8' or 8' x 4' sheets in 1/4", 1/2" or 3/4" thicknesses. Face will be A grade veneer with raw edges and #2 backs. A grade back option available on 3/4" sheets.

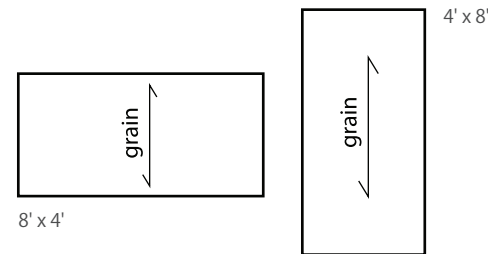

NORLAM

We offer A grade veneer applied to a semi-rigid backer that can be applied with contact adhesive. Available in 4' x 8' sheets.

PSA

We offer A grade veneer with a pressure sensitive adhesive developed specifically for cabinet refacing applications. Available in 4' x 8' or two 2' x 8' sheets.

NATURAL SPECIES

RIFT RED OAK



Face: A grade rift cut heartwood
Back: #2 grade, some sapwood
Edge: Red Oak
Characteristics: Light yellowish-tan to light brown; straight, consistent grain

PLAIN SLICED RED OAK



Face: A grade plain sliced heartwood
Back: #2 grade, some sapwood
Edge: Red Oak
Characteristics: Light tan to pinkish-brown; coarse textured

QTRD BLACK WALNUT



Face: A grade quarter sawn heartwood
Back: #2 grade, some sapwood
Edge: Walnut
Characteristics: Light Grey-brown to rich chocolate-brown to deep purplish-brown with caramel streaks; straight to interlocked or wavy grain pattern and may contain slight mottle figure

PLAIN SLICED BLACK WALNUT



Face: A grade plain sliced heartwood
Back: #2 grade, some sapwood
Edge: Walnut
Characteristics: Light Grey-brown to rich chocolate-brown to deep purplish-brown with caramel streaks; straight to interlocked or wavy grain pattern and may contain slight mottle figure

QTRD MAPLE



Face: A grade
Back: #2 grade
Characteristics: Light yellowish-tan to light brown; coarse textured with straight grain pattern

PLAIN SLICED MAPLE



Face: A grade plain sliced sapwood
Back: #2 grade sapwood
Edge: Maple
Characteristics: White to creamy white, may have a pinkish tinge; may contain slight curly or crossfire figure

QTRD CHERRY



Face: A grade quarter sawn heartwood
Back: #2 grade, some sapwood
Edge: Cherry
Characteristics: Light pinkish-brown to dark reddish-brown

PLAIN SLICED CHERRY



Face: A grade plain sliced heartwood
Back: #2 grade, some sapwood
Edge: Cherry
Characteristics: Light pinkish-brown to dark reddish-brown

PLAIN SLICED WHITE OAK



Face: A grade plain sliced heartwood
Back: #2 grade, some sapwood
Edge: White Oak
Characteristics: Light yellowish-tan to light brown; coarse textured

RIFT WHITE OAK



Face: A grade rift cut heartwood
Back: #2 grade, some sapwood
Edge: White Oak
Characteristics: Light yellowish-tan to light brown; coarse textured with straight grain pattern

QTRD FLAKEY WHITE OAK



Face: A grade quarter sawn heartwood with ray fleck figure
Back: #2 grade White Oak, some sapwood
Edge: White Oak
Characteristics: Random matched, yellowish-tan to light brown; medium to heavy ray fleck figure

AMERICAN RED GUM



Face: A grade mix of quarter sawn and rift cut heartwood and sapwood
Back: #2 grade mix of quarter sawn and rift cut heartwood and sapwood
Edge: Cherry
Characteristics: Random matched, varies widely within a single piece, ranging from creamy-white to dull pinkish-brown with dark streaks; irregular grain pattern may contain pigment figure

RECONSTITUTED SPECIES

RIFT WHITE OAK



Edge: White Oak
Characteristics: Light yellowish-tan to light brown; straight, consistent grain

NORDIC SG



Edge: Nordic SG
Characteristics: Light tan; straight, consistent grain

LINCOLN OAK



Edge: Lincoln Oak
Characteristics: Light tan to medium brown; straight to interlocked or wavy grain

BAMBOO



Edge: Bamboo
Characteristics: Caramelized light honey to dark amber; straight, consistent grain pattern with nodules randomly interspersed throughout

TERRA SG

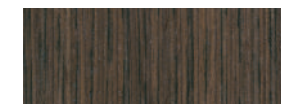

Edge: Terra SG
Characteristics: Medium to dark brown grey; straight, consistent grain

SMOKED GREY

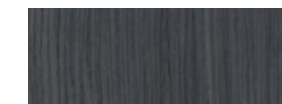

Edge: Smoked Grey
Characteristics: Grey tones from light to medium to dark; straight, consistent grain

METRO

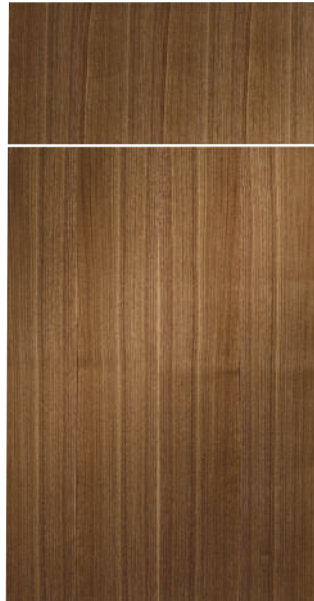

QUARTERED BLACK WALNUT

Door | Drawer Front

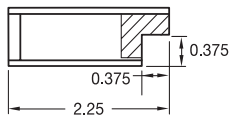

Frame

PROFILE SPECIFICATIONS

DOOR STYLE	Slab
CONSTRUCTION	Internally edgebanded, membrane pressed face and back
FACE MATERIAL	Natural and Reconstituted species
EDGE BANDING	Species specific wood veneer
BACK MATERIAL	Species specific wood veneer
CORE	3/4" engineered core 3/4" ULEF core available
GRAIN DIRECTION	Vertical grain is standard on doors, drawer fronts and frames Horizontal grain available

ADDITIONAL OPTIONS

ROUTE FOR INSERT	Standard frame route for insert shown T-slot route available
HINGE BORING	See page 3 for standard patterns and placement Custom drilling available
MODIFICATIONS	Stile and rail widths on frames can be altered
PAINT GRADE	Paint Grade Maple available

SIZE PARAMETERS

DOORS DRAWER FRONTS	6" x 6" minimum 48" x 96" maximum, warranted to 30" x 72"
OVERLAYS	2.875" x 6" minimum
FRAMES	7" x 7" minimum 30" x 72" maximum
INSERT SIZING	For Standard or T-slot route subtract 3.875" from width and height to determine insert size with 1/16" clearance on all sides



KITCHEN: METRO | SMOKED GREY
SHELVING: RIFT CUT WHITE OAK

FUSION



PLAIN SLICED BLACK WALNUT

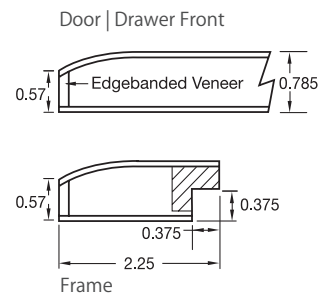

PROFILE SPECIFICATIONS

DOOR STYLE	Slab
CONSTRUCTION	Internally edgebanded, membrane pressed face and back
FACE MATERIAL	Natural and Reconstituted species
EDGE BANDING	Species specific wood veneer
BACK MATERIAL	Species specific wood veneer
CORE	3/4" engineered core 3/4" ULEF core available
GRAIN DIRECTION	Vertical grain is standard on doors, drawer fronts and frames Horizontal grain available

ADDITIONAL OPTIONS

ROUTE FOR INSERT	Standard frame route for insert shown T-slot route available
HINGE BORING	See page 3 for standard patterns and placement Custom drilling available
MODIFICATIONS	Stile and rail widths on frames can be altered
PAINT GRADE	Paint Grade Maple available

SIZE PARAMETERS

DOORS DRAWER FRONTS	6" x 6" minimum 48" x 96" maximum, warranted to 30" x 72"
OVERLAYS	2.875" x 6" minimum
FRAMES	7" x 7" minimum 30" x 72" maximum
INSERT SIZING	For Standard or T-slot route subtract 3.875" from width and height to determine insert size with 1/16" clearance on all sides

NOVA



RIFT RED OAK

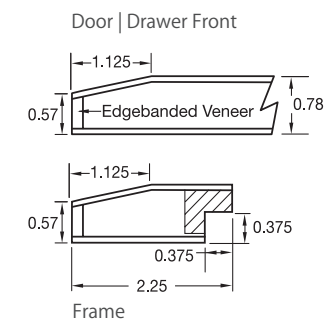

PROFILE SPECIFICATIONS

DOOR STYLE	Slab
CONSTRUCTION	Internally edgebanded, membrane pressed face and back
FACE MATERIAL	Natural and Reconstituted species
EDGE BANDING	Species specific wood veneer
BACK MATERIAL	Species specific wood veneer
CORE	3/4" engineered core 3/4" ULEF core available
GRAIN DIRECTION	Vertical grain is standard on doors, drawer fronts and frames Horizontal grain available

ADDITIONAL OPTIONS

ROUTE FOR INSERT	Standard frame route for insert shown T-slot route available
HINGE BORING	See page 3 for standard patterns and placement Custom drilling available
MODIFICATIONS	Stile and rail widths on frames can be altered
PAINT GRADE	Paint Grade Maple available

SIZE PARAMETERS

DOORS DRAWER FRONTS	6" x 6" minimum 48" x 96" maximum, warranted to 30" x 72"
OVERLAYS	2.875" x 6" minimum
FRAMES	7" x 7" minimum 30" x 72" maximum
INSERT SIZING	For Standard or T-slot route subtract 3.875" from width and height to determine insert size with 1/16" clearance on all sides

FLOATING SHELVES

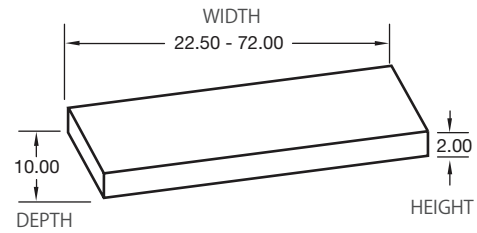

SPECIFICATIONS	
CONSTRUCTION	Miter folded, internal metal bracket included with your order
FACE MATERIAL	All 3D Laminates High Gloss Wired 2D Laminates All Wood Veneer, including paint grade Maple
CORE	Engineered core
GRAIN DIRECTION	Standard grain direction will be horizontal on top, bottom and front edge. Both ends will have vertical grain. Optional horizontal grain on top, bottom and all edges.
SIZE PARAMETERS	
STANDARD WIDTH	22.5" minimum 72" maximum
STANDARD DEPTH	10"
STANDARD HEIGHT	2"
MAX LOAD	10 lbs per lineal foot

FLOATING SHELF INTERNAL BRACKET

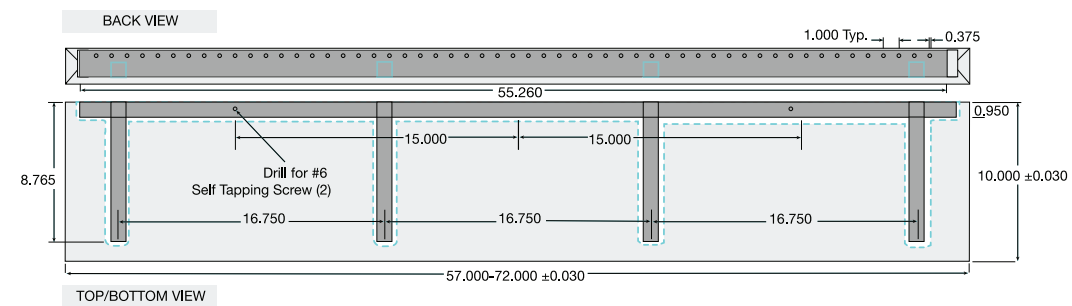
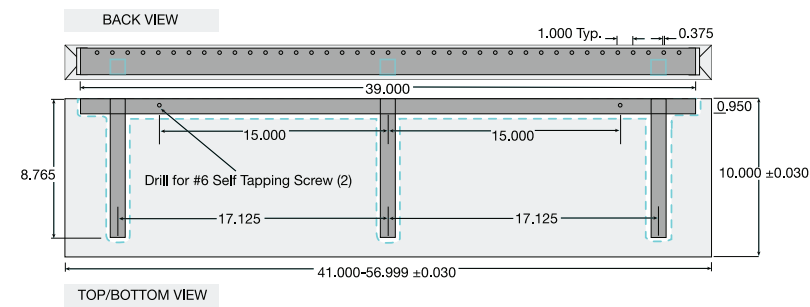
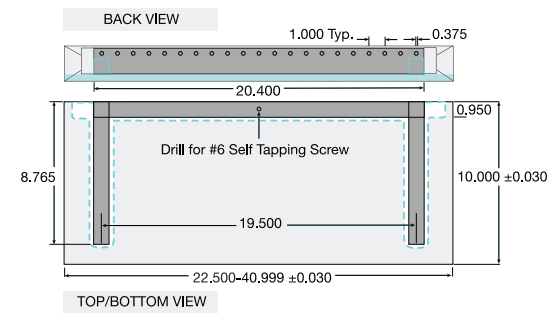

Custom Routing Available
FOR CUSTOMER-SUPPLIED BRACKETS



BLACK WALNUT + WHITE GLOSS



MAJESTIC WALNUT

KITCHEN: METRO | SMOKED GREY
SHELVING: RIFT CUT WHITE OAK





NORTHERN CONTOURS, INC.
1355 Mendota Heights Rd., #100, St. Paul, MN 55120
Customer Care 877-998-1814
www.northerncontours.com

ML1010102 202503